



UFDW



**Aero extractor-inyector centrífugo ATC
Doble ancho, doble entrada línea industrial
álabes planos atrasados**

ATC industrial double width, double inlet centrifugal fans
Backward inclined wheels



The Right Choice



UFDW

Aero extractor-inyector centrífugo ATC, doble ancho, doble entrada línea industrial álabes planos atrasados

La gama UFDW de los Aero Ventiladores centrífugos de doble ancho, doble entrada Mca. ATC con transmisión de poleas y bandas, ha sido específicamente diseñada para inyección y extracción de aire en sistemas de ventilación, calefacción y aire acondicionado en aplicaciones comerciales e industriales; se compone de 9 modelos con diámetros de turbina desde 10 1/4" hasta 24 5/8" en doble ancho, distintas clases constructivas, rotaciones y diferentes posiciones de descarga, ofreciendo la línea de los ventiladores centrífugos más versátil, eficiente y silenciosa con el rango más amplio en prestaciones de caudal-presión en el mercado.

Características principales

- Conjunto carcasa, cono de succión y soporte de transmisión-motor y estructural fabricado en acero al carbón o acero inoxidable de diferentes calibres según tipo de clase del ventilador (I-II).
- Turbina centrífuga de doble ancho y de alta eficiencia y operación silenciosa con alabes planos atrasados estática y dinámicamente balanceada, fabricada en acero al carbón, acero inoxidable ó aluminio según aplicaciones.
- El proceso de prepintado con tratamientos químicos y posteriormente la aplicación electrostática de pintura poliéster en polvo horneada altamente resistente a la corrosión e intemperie en todos los componentes de los ventiladores centrífugos es estándar.
- Disponible en 7 diferentes posiciones de descarga (TH, BH, UB, DB, TAD, BAU, TAU) con 2 distintas rotaciones del rotor (CW – CCW).
- Chumaceras o Rodamientos de alta eficiencia y mínimo mantenimiento, diseñados para aplicaciones de servicio pesado adquiridos de los fabricantes mundialmente reconocidos.
- Flechas o ejes impulsores seleccionados en diferentes diámetros y longitudes según tamaño y clase del ventilador, fabricados en acero AISI C-1045, perfectamente pulidos y rectificadas en toda su longitud y protegidos con un recubrimiento anticorrosivo.
- Base ajustable de motor fabricada en acero al carbón y diseñada para ajuste, alineación y tensión de las bandas con una precisión y rapidez.

- Accionado por transmisión de poleas y bandas a los motores eléctricos de eficiencia premium, permite lograr las distintas relaciones de caudal-presión ofreciendo el ventilador centrífugo más versátil y vendido en el mundo.
- Construcción anti-chispa según clasificaciones de AMCA.
 - Tipo A - Todos los componentes del ventilador en contacto con aire o gas deben ser construidos de material no ferroso.
 - Tipo B - Turbina y disco anti-chispa colocado dentro de la carcasa del ventilador por donde pasa la flecha deben ser construidos de material no ferroso.
 - Tipo C – El ventilador debe ser construido de tal forma, evitando cualquier contacto o fricción entre 2 partes ferrosos por un desplazamiento del rotor o flecha.

Accesorios disponibles

- Registro o Puerta de Inspección.
- Tubo de Dren.
- Disco de Enfriamiento.
- Tacones o resortes antivibratorios.
- Malla de protección en succión o descarga.
- Bridas en descarga.
- Construcción anti-chispa.
- Recubrimientos especiales para aplicaciones de alta resistencia a la corrosión ó temperatura.

Nomenclatura

UFDW - 16 - CW - II

1	2	3	4
---	---	---	---

1. Modelo del Ventilador.
2. Tamaño del Ventilador.
3. Rotación de la turbina:
CW - Sentido Reloj
CCW - Sentido contra Reloj
4. Clase Constructiva del Ventilador
I – Clase I
II – Clase II



UFDW

ATC industrial double width, double inlet centrifugal fans Backward inclined wheels

The UFDW series are heavy duty double width, double inlet (DWDI), belt drive supply and exhaust fans designed for heating, ventilation and air conditioning systems, class I and class II performance in commercial and industrial applications. ATC DWDI fans are available in 9 models with Wheel diameters from 10 1/4" through 24 5/8", different performance classes, rotations and discharge positions, offering the line of most versatile, quiet, energy efficient fans which can handle a wide range of air flow and pressure in the global market.

Construction features

- Housings, inlet cones, drive and motor stands are made of air tight heavy gauge all welded steel or stainless steel construction.
- Backward inclined double width non-overloading wheels are constructed with welded steel, stainless steel or aluminum, statically and dynamically balanced at the factory and designed for optimum performance for most operating conditions.
- Electrostatically applied powder coating is Standard on all ATC fans. For special requirements, please contact the factory.
- The fans are field rotatable to seven standard discharges (TH, DB, UB, TAD, BAU, TAU) and are available with clockwise (CW) or counter clockwise (CCW) wheel rotation.
- Self-aligning heavy duty, pillow blocks ball bearings are designed to operate under the most severe atmospheric conditions and are supplied by the most prestigious world wide manufacturers.
- Shafts are designed for long life in different diameters and lengths, turned, ground and polished of solid SAE 1045 steel for smooth operation, key-wayed on each end and are protected with a corrosion resistant coating.
- Adjustable steel motor plate pivoted at one end for ease of belt tensioning.
- The UFDW series are the ideal choice for the general ventilation applications, using the combination of high quality sheaves, v-belts, premium efficiency motors in order to handle a wide range of air volumes and pressures.
- AMCA classifications for spark resistant construction where hazardous, explosive or flammable conditions exist.

Type A – All parts of the fan in contact with the air or gas being handled shall be made of non-ferrous material.

Type B – The fan shall have a non-ferrous wheel and non-ferrous ring or rubbing plate about the opening through which the shaft passes. Ferrous hubs, shafts and hardware are permitted.

Type C – The fan shall be so constructed that a shift of the Wheel or shaft will not permit two ferrous parts of the fan to rub or strike. Fans for this condition will be furnished with a non-ferrous inlet cone and rubbing plate around the shaft opening.

Optional Accessories

- Access or clean-out doors.
- Drains.
- Shaft Coolers.
- Vibration Isolators.
- Inlet & outlet screens.
- Flanged outlet.
- Spark resistant construction.
- Special protective coating for corrosion and high temperature.

Nomenclature

UFDW - 16 - CW - II

1

2

3

4

1. Fan model.
2. Fan size.
3. Impeller rotation:
CW - Clockwise
CCW – Counter clockwise
4. Fan class.
I – Class I
II – Class II



UFDW-10

Diámetro de la Turbina = 10 1/4"
 Área de Descarga = 1.064 ft²
 Rpm Max = Clase I 3200 Clase II 3900
 Velocidad Tangencial (FPM) = 2.683 x Rpm
 Max. BHP = 0.052 (Rpm/1000)³
 Peso Aprox. (Sin Motor) = 36 Kg (79Lb)

Wheel Diameter = 10 1/4"
 Discharge Area = 1.064 ft²
 Max Rpm = Clase I 3200 Clase II 3900
 Tip Speed (FPM) = 2.683 x Rpm
 Max. BHP = 0.052 (Rpm/1000)³
 Approx. Ship WT. (Less Motor) = 36 Kg (79Lb)

Caudal (Airflow)		Vel.	Presión Estática en Pulgadas C.A. (Static Pressure in Inches W. G.)																							
CFM	m ³ /HR		0.50"		1.00"		1.50"		2.00"		2.50"		3.00"		3.50"		4.00"		4.50"		5.00"		6.00"			
		FPM	Rpm	BHP	Rpm	BHP	Rpm	BHP	Rpm	BHP	Rpm	BHP	Rpm	BHP	Rpm	BHP	Rpm	BHP	Rpm	BHP	Rpm	BHP	Rpm	BHP		
851	1446	800	1263	0.10	1660	0.21	2012	0.34	2325	0.49	2606	0.65	2863	0.82	3100	1.01	3321	1.20	3529	1.40	3725	1.61	4091	2.04		
1064	1808	1000	1385	0.14	1724	0.26	2038	0.39	2328	0.55	2597	0.72	2846	0.91	3079	1.10	3298	1.31	3504	1.53	3700	1.75	4065	2.22		
1277	2170	1200	1530	0.18	1824	0.31	2101	0.46	2364	0.62	2613	0.80	2850	1.00	3073	1.21	3285	1.42	3487	1.65	3680	1.89	4042	2.39		
1490	2532	1400	1687	0.24	1949	0.38	2195	0.54	2432	0.71	2660	0.90	2879	1.10	3089	1.32	3292	1.55	3486	1.78	3673	2.03	4026	2.56		
1702	2892	1600	1853	0.31	2090	0.47	2312	0.63	2526	0.82	2733	1.01	2935	1.23	3131	1.45	3321	1.69	3505	1.93	3683	2.19	4024	2.73		
1915	3254	1800	2026	0.40	2242	0.57	2445	0.75	2640	0.94	2830	1.15	3015	1.37	3196	1.60	3373	1.84	3546	2.10	3715	2.37	4040	2.93		
2128	3615	2000	2201	0.50	2402	0.69	2590	0.88	2770	1.09	2944	1.30	3115	1.53	3283	1.78	3447	2.03	3609	2.29	3767	2.57	4075	3.14		
2341	3977	2200	2376	0.62	2569	0.83	2743	1.03	2910	1.25	3072	1.48	3231	1.72	3386	1.98	3540	2.24	3690	2.51	3839	2.79	4130	3.38		
2554	4339	2400	2557	0.76	2738	0.98	2903	1.21	3059	1.44	3211	1.69	3359	1.94	3504	2.20	3647	2.47	3789	2.75	3928	3.04	4201	3.65		
2766	4699	2600	2739	0.93	2910	1.17	3067	1.41	3214	1.66	3357	1.92	3497	2.18	3633	2.45	3767	2.74	3900	3.03	4031	3.33				
2979	5061	2800	2918	1.11	3086	1.37	3235	1.63	3375	1.90	3510	2.17	3642	2.45	3771	2.74	3898	3.03	4023	3.33	4146	3.64				
3192	5423	3000	3096	1.32	3265	1.61	3405	1.89	3540	2.17	3668	2.45	3793	2.75	3916	3.05	4036	3.35	4154	3.67						
3405	5785	3200	3284	1.56	3444	1.87	3578	2.17	3706	2.46	3830	2.77	3949	3.07	4066	3.39	4181	3.71								

UFDW-12

Diámetro de la Turbina = 12 1/2"
 Área de Descarga = 1.573 ft²
 Rpm Max = Clase I 3100 Clase II 3800
 Velocidad Tangencial (FPM) = 3.272 x Rpm
 Max. BHP = 0.144 (Rpm/1000)³
 Peso Aprox. (Sin Motor) = 48 Kg (106Lb)

Wheel Diameter = 12 1/2"
 Discharge Area = 1.573 ft²
 Max. Rpm = Class I 3100 Class II 3800
 Tip Speed (FPM) = 3.272 x Rpm
 Max. BHP = 0.144 (Rpm/1000)³
 Approx. Ship WT. (Less Motor) = 48 Kg (106Lb)

Caudal (Airflow)		Vel.	Presión Estática en Pulgadas C.A. (Static Pressure in Inches W. G.)																							
CFM	m ³ /HR		0.50"		1.00"		1.50"		2.00"		2.50"		3.00"		3.50"		4.00"		4.50"		5.00"		6.00"			
		FPM	Rpm	BHP	Rpm	BHP	Rpm	BHP	Rpm	BHP	Rpm	BHP	Rpm	BHP	Rpm	BHP	Rpm	BHP	Rpm	BHP	Rpm	BHP	Rpm	BHP		
1258	2137	800	1035	0.16	1357	0.32	1643	0.52	1898	0.74	2127	0.98	2336	1.24	2530	1.52	2710	1.81	2880	2.11	3040	2.42	3339	3.08		
1573	2672	1000	1137	0.21	1411	0.39	1666	0.60	1902	0.83	2120	1.09	2323	1.37	2513	1.66	2691	1.98	2860	2.30	3019	2.64	3317	3.34		
1888	3208	1200	1256	0.28	1494	0.47	1715	0.69	1932	0.94	2135	1.21	2327	1.51	2509	1.82	2682	2.15	2846	2.49	3004	2.85	3298	3.60		
2202	3741	1400	1386	0.36	1598	0.58	1797	0.81	1989	1.08	2174	1.36	2352	1.67	2523	1.99	2688	2.33	2847	2.69	2998	3.06	3286	3.85		
2517	4276	1600	1522	0.47	1715	0.71	1894	0.96	2068	1.24	2236	1.53	2400	1.85	2559	2.19	2713	2.54	2863	2.92	3008	3.30	3286	4.12		
2831	4810	1800	1664	0.61	1840	0.86	2005	1.13	2163	1.43	2316	1.74	2467	2.07	2614	2.42	2757	2.79	2898	3.17	3035	3.57	3300	4.41		
3146	5345	2000	1805	0.76	1970	1.04	2122	1.33	2268	1.65	2410	1.97	2548	2.32	2685	2.68	2818	3.06	2950	3.46	3079	3.87	3329	4.74		
3461	5880	2200	1943	0.93	2101	1.24	2243	1.56	2379	1.89	2511	2.24	2640	2.60	2767	2.97	2892	3.37	3015	3.77	3136	4.20	3373	5.09		
3775	6414	2400	2094	1.15	2241	1.49	2375	1.83	2503	2.18	2626	2.55	2747	2.93	2865	3.32	2981	3.73	3096	4.15	3210	4.59	3433	5.50		
4090	6949	2600	2248	1.41	2386	1.77	2514	2.14	2634	2.51	2750	2.90	2863	3.30	2974	3.71	3083	4.14	3191	4.58	3297	5.03	3507	5.97		
4404	7482	2800	2386	1.67	2523	2.07	2644	2.46	2759	2.86	2869	3.27	2976	3.69	3081	4.12	3185	4.56	3287	5.01	3388	5.49	3586	6.45		
4719	8018	3000	2524	1.97	2661	2.41	2777	2.82	2886	3.24	2991	3.67	3093	4.11	3193	4.56	3292	5.02	3389	5.49	3484	5.97	3673	6.98		
5034	8553	3200	2678	2.34	2807	2.80	2917	3.24	3022	3.69	3123	4.14	3221	4.60	3316	5.07	3410	5.55	3502	6.04	3593	6.54	3772	7.58		

UFDW-13

Diámetro de la Turbina = 14"
 Área de Descarga = 1.986 ft²
 Rpm Max = Clase I 3900 Clase II 3500
 Velocidad Tangencial (FPM) = 3.665 x Rpm
 Max. BHP = 0.233 (Rpm/1000)³
 Peso Aprox. (Sin Motor) = 62Kg (136Lb)

Wheel Diameter = 14"
 Discharge Area = 1.986 ft²
 Max. Rpm = Class I 2900 Class II 3500
 Tip Speed (FPM) = 3.665 x Rpm
 Max. BHP = 0.233 (Rpm/1000)³
 Approx. Ship WT. (Less Motor) = 62Kg (136Lb)

Caudal (Airflow)		Vel.	Presión Estática en Pulgadas C.A. (Static Pressure in Inches W. G.)																							
CFM	m ³ /HR		0.50"		1.00"		1.50"		2.00"		2.50"		3.00"		3.50"		4.00"		4.50"		5.00"		6.00"			
		FPM	Rpm	BHP	Rpm	BHP	Rpm	BHP	Rpm	BHP	Rpm	BHP	Rpm	BHP	Rpm	BHP	Rpm	BHP	Rpm	BHP	Rpm	BHP	Rpm	BHP		
1589	2700	800	952	0.20	1237	0.40	1492	0.64	1721	0.91	1929	1.21	2118	1.52	2294	1.86	2457	2.21	2611	2.58	2757	2.97	3027	3.77		
1986	3374	1000	1050	0.27	1289	0.48	1516	0.74	1728	1.03	1924	1.34	2108	1.68	2279	2.05	2440	2.43	2593	2.82	2738	3.24	3008	4.10		
2383	4049	1200	1167	0.36	1371	0.59	1570	0.87	1760	1.17	1942	1.50	2114	1.86	2278	2.24	2433	2.64	2582	3.06	2724	3.50	2990	4.42		
2780	4723	1400	1284	0.47	1470	0.73	1647	1.02	1818	1.34	1983	1.69	2141	2.06	2295	2.46	2442	2.88	2584	3.32	2721	3.78	2981	4.74		
3178	5085	1600	1412	0.61	1582	0.90	1742	1.21	1896	1.55	2047	1.93	2188	2.32	2334	2.71	2473	3.17	2605	3.62	2735	4.09	2985	5.08		
3575	6074	1800	1546	0.78	1700	1.10	1848	1.43	1989	1.81	2125	2.19	2258	2.60	2390	3.03	2515	3.48	2640	3.93	2765	4.44	3002	5.47		
3972	6748	2000	1680	0.99	1825	1.33	1960	1.70	2089	2.10	2214	2.51	2340	2.93	2460	3.38	2580	3.85	2696	4.33	2811	4.81	3035	5.90		
4369	7423	2200	1817	1.24	1957	1.63	2079	2.00	2200	2.41	2315	2.85	2431	3.29	2540	3.78	2655	4.26	2761	4.76	2872	5.28	3080	6.38		
4766	8097	2400	1950	1.50	2090	1.95	2208	2.39	2318	2.80	2428	3.27	2535	3.75	2640	4.20	2740	4.73	2843	5.25	2942	5.80	3140	6.88		
5164	8774	2600	2088	1.83	2220	2.30	2335	2.78	2440	3.25	2542	3.70	2640	4.20	2742	4.71	2835	5.25	2933	5.80	3025	6.35	3215	7.50		
5561	9448	2800	2235	2.24	2355	2.72	2461	3.21	2565	3.70	2660	4.23	2754	4.75	2850	5.30	2942	5.84	3030	6.40	3120	6.96	3295	8.18		
5958	10123	3000	2380	2.67	2490	3.20	2598	3.73	2693	4.25	2780	4.80	2875	5.35	2965	5.91	3050	6.50	3137	7.10	3220	7.68	3390	8.90		
6355	10797	3200	2512	3.13	2630	3.70	2730	4.30	2825	4.85	2911	5.44	2997	6.00	3080	6.60	3165	7.20	3245	7.80	3325	8.45	3480	9.71		



UFDW-15

Diámetro de la Turbina = 15 1/8"
 Área de Descarga= 2.373 ft²
 Rpm Max= Clase I 2700 Clase II 3200
 Velocidad Tangencial (FPM) = 3.959 x Rpm
 Max. BHP= 0.445 (Rpm/1000)³
 Peso Aprox. (Sin Motor) = 74 Kg (163Lb)

Wheel Diameter = 15 1/8"
 Discharge Area= 2.373 ft²
 Rpm Max= Clase I 2700 Clase II 3200
 Tip Speed (FPM)= 3.959 x Rpm
 Max. BHP= 0.445 (Rpm/1000)³
 Approx. Ship WT. (Less Motor) = 74 Kg (163Lb)

Caudal (Airflow)		Vel.	Presión Estática en Pulgadas C.A. (Static Pressure in Inches W. G.)																							
CFM	m ³ /HR		0.50"		1.00"		1.50"		2.00"		2.50"		3.00"		3.50"		4.00"		4.50"		5.00"		6.00"			
		FPM	Rpm	BHP	Rpm	BHP	Rpm	BHP	Rpm	BHP	Rpm	BHP	Rpm	BHP	Rpm	BHP	Rpm	BHP	Rpm	BHP	Rpm	BHP	Rpm	BHP		
1898	3225	800	825	0.25	1102	0.51	1335	0.84	1540	1.21	1723	1.59	1890	2.05	2040	2.50	2188	3.00	2319	3.50	2445	4.04	2682	5.17		
2373	4032	1000	897	0.32	1130	0.61	1350	0.95	1545	1.34	1725	1.77	1888	2.21	2038	2.70	2182	3.23	2315	3.78	2442	4.34	2674	5.55		
2848	4839	1200	985	0.43	1188	0.73	1380	1.08	1565	1.50	1733	1.95	1891	2.41	2040	2.92	2183	3.49	2310	4.06	2439	4.65	2669	5.86		
3322	5644	1400	1084	0.56	1260	0.89	1435	1.27	1600	1.70	1758	2.14	1905	2.66	2050	3.20	2185	3.75	2314	4.31	2440	4.95	2670	6.25		
3797	6451	1600	1188	0.72	1345	1.09	1500	1.50	1650	1.94	1795	2.42	1938	2.94	2069	3.45	2200	4.06	2330	4.68	2450	5.30	2675	6.66		
4271	7256	1800	1298	0.92	1440	1.34	1580	1.75	1715	2.21	1850	2.72	1979	3.25	2100	3.79	2230	4.43	2348	5.04	2466	5.70	2684	7.10		
4746	8063	2000	1404	1.14	1540	1.60	1668	2.07	1790	2.55	1915	3.08	2034	3.63	2150	4.20	2265	4.80	2380	5.46	2490	6.12	2699	7.55		
5221	8870	2200	1520	1.43	1646	1.92	1760	2.42	1875	2.91	1988	3.49	2100	4.06	2208	4.64	2316	5.30	2420	5.95	2525	6.63	2729	8.09		
5695	9676	2400	1630	1.72	1750	2.30	1860	2.81	1968	3.37	2070	3.95	2175	4.55	2272	5.15	2370	5.80	2475	6.50	2570	7.20	2766	8.70		
6170	10483	2600	1755	2.10	1860	2.70	1960	3.26	2065	3.90	2158	4.45	2257	5.10	2350	5.75	2442	6.40	2540	7.14	2630	7.85	2810	9.36		
6644	11288	2800	1866	2.50	1970	3.15	2069	3.78	2160	4.40	2252	5.05	2345	5.73	2431	6.37	2520	7.10	2609	7.80	2697	8.55	2870	10.11		
7119	12095	3000	1983	2.96	2090	3.70	2180	4.37	2266	5.05	2350	5.70	2440	6.40	2520	7.11	2604	7.85	2690	8.58	2770	9.35	2929	10.92		
7594	12902	3200	2110	3.53	2200	4.30	2289	5.00	2368	5.70	2450	6.41	2535	7.15	2609	7.87	2690	8.65	2766	9.40	2847	10.22	3000	11.81		

UFDW-16

Diámetro de la Turbina = 16 11/16"
 Área de Descarga= 2.878 ft²
 Rpm Max= Clase I 2400 Clase II 2900
 Velocidad Tangencial (FPM) = 4.369 x Rpm
 Max. BHP= 0.706 (Rpm/1000)³
 Peso Aprox. (Sin Motor) = 82Kg (180Lb)

Wheel Diameter = 16 11/16"
 Discharge Area= 2.878 ft²
 Max. Rpm= Class I 2400 Class II 2900
 Tip Speed (FPM)= 4.369 x Rpm
 Max. BHP= 0.706 (Rpm/1000)³
 Approx. Ship WT. (Less Motor) = 82Kg (180Lb)

Caudal (Airflow)		Vel.	Presión Estática en Pulgadas C.A. (Static Pressure in Inches W. G.)																							
CFM	m ³ /HR		0.50"		1.00"		1.50"		2.00"		2.50"		3.00"		3.50"		4.00"		4.50"		5.00"		6.00"			
		FPM	Rpm	BHP	Rpm	BHP	Rpm	BHP	Rpm	BHP	Rpm	BHP	Rpm	BHP	Rpm	BHP	Rpm	BHP	Rpm	BHP	Rpm	BHP	Rpm	BHP		
2302	3911	800	765	0.31	1015	0.63	1224	1.00	1410	1.45	1570	1.90	1719	2.42	1860	2.98	1990	3.56	2113	4.16	2227	4.77	2440	6.14		
2878	4890	1000	841	0.42	1045	0.75	1239	1.15	1420	1.63	1579	2.13	1725	2.69	1860	3.25	1990	3.87	2112	4.50	2225	5.18	2439	6.56		
3454	5868	1200	925	0.56	1105	0.93	1280	1.36	1440	1.85	1595	2.39	1736	2.95	1869	3.56	1993	4.19	2113	4.88	2226	5.55	2440	7.05		
4029	6845	1400	1028	0.76	1180	1.16	1335	1.61	1481	2.11	1620	2.67	1757	3.26	1880	3.90	2005	4.55	2120	5.26	2235	6.00	2439	7.52		
4605	7824	1600	1131	1.00	1265	1.42	1400	1.90	1535	2.45	1663	3.01	1790	3.65	1910	4.29	2024	4.96	2135	5.70	2244	6.45	2447	8.05		
5180	8801	1800	1236	1.30	1360	1.77	1485	2.30	1600	2.84	1720	3.42	1836	4.07	1947	4.75	2056	5.45	2160	6.20	2265	7.00	2462	8.63		
5756	9779	2000	1344	1.65	1461	2.19	1575	2.75	1679	3.32	1790	3.94	1892	4.60	1995	5.30	2099	6.02	2200	6.80	2296	7.60	2483	9.26		
6332	10758	2200	1460	2.10	1566	2.67	1665	3.26	1767	3.89	1861	4.50	1960	5.20	2056	5.92	2154	6.69	2245	7.45	2338	8.28	2517	10.00		
6907	11735	2400	1570	2.60	1670	3.21	1765	3.85	1857	4.51	1945	5.18	2040	5.92	2126	6.65	2215	7.42	2300	8.22	2390	9.08	2558	10.80		
7483	12714	2600	1690	3.19	1781	3.88	1864	4.54	1949	5.22	2039	5.96	2120	6.70	2200	7.48	2285	8.26	2369	9.11	2450	9.98	2610	11.90		
8058	13690	2800	1803	3.85	1890	4.60	1970	5.30	2048	6.04	2130	6.80	2210	7.60	2283	8.37	2365	9.24	2440	10.02	2512	11.00	2670	12.90		
8634	14669	3000	1910	4.56	2000	5.41	2080	6.20	2155	6.99	2230	7.79	2300	8.60	2375	9.44	2445	10.40	2520	11.30	2590	12.20	2735	14.03		
9210	15648	3200	2041	5.53	2120	6.38	2189	7.18	2260	8.01	2330	8.85	2400	9.72	2466	10.60	2536	11.60	2605	12.50	2670	13.30	2806	15.50		

UFDW-18

Diámetro de la Turbina = 18 9/16"
 Área de Descarga= 3.566 ft²
 Rpm Max= Clase I 2100 Clase II 2600
 Velocidad Tangencial (FPM) = 4.860 x Rpm
 Max. BHP= 1.075 (Rpm/1000)³
 Peso Aprox. (Sin Motor) = 96 Kg (211Lb)

Wheel Diameter = 18 9/16"
 Discharge Area= 3.566 ft²
 Max. Rpm= Class I 2100 Class II 2600
 Tip Speed (FPM)= 4.860 x Rpm
 Max. BHP= 1.075 (Rpm/1000)³
 Approx. Ship WT. (Less Motor) = 96 Kg (211Lb)

Caudal (Airflow)		Vel.	Presión Estática en Pulgadas C.A. (Static Pressure in Inches W. G.)																							
CFM	m ³ /HR		0.50"		1.00"		1.50"		2.00"		2.50"		3.00"		3.50"		4.00"		4.50"		5.00"		6.00"			
		FPM	Rpm	BHP	Rpm	BHP	Rpm	BHP	Rpm	BHP	Rpm	BHP	Rpm	BHP	Rpm	BHP	Rpm	BHP	Rpm	BHP	Rpm	BHP	Rpm	BHP		
2853	4847	800	675	0.32	915	0.68	1117	1.12	1290	1.63	1445	2.17	1579	2.74	1710	3.38	1827	4.02	1939	4.72	2050	5.46	2246	7.00		
3566	6059	1000	725	0.41	930	0.80	1120	1.26	1287	1.79	1443	2.39	1580	3.00	1705	3.65	1825	4.37	1935	5.10	2043	5.87	2236	7.45		
4279	7270	1200	790	0.52	960	0.94	1137	1.44	1295	2.00	1440	2.60	1580	3.27	1702	3.95	1820	4.69	1930	5.45	2041	6.27	2240	7.96		
4992	8481	1400	859	0.67	1013	1.11	1167	1.64	1310	2.21	1449	2.85	1581	3.55	1705	4.27	1821	5.04	1936	5.87	2040	6.70	2234	8.46		
5706	9694	1600	945	0.87	1081	1.35	1214	1.89	1345	2.50	1469	3.14	1595	3.88	1715	4.65	1830	5.45	1935	6.26	2041	7.15	2236	8.99		
6415	10899	1800	1030	1.11	1150	1.60	1269	2.19	1388	2.82	1501	3.48	1615	4.22	1730	5.01	1841	5.87	1940	6.70	2042	7.61	2235	9.53		
7132	12117	2000	1118	1.38	1230	1.95	1337	2.55	1440	3.20	1545	3.89	1650	4.65	1753	5.45	1860	6.34	1961	7.22	2050	8.12	2241	10.10		
7845	13329	2200	1208	1.71	1310	2.33	1409	2.97	1502	3.63	1600	4.37	1695	5.14	1795	5.98	1890	6.88	1979	7.75	2070	8.70	2252	10.72		
8558	14540	2400	1297	2.08	1390	2.74	1486	3.44	1569	4.14	1658	4.90	1750	5.72	1841	6.58	1925	7.45	2016	8.40	2098	9.34	2271	11.50		
9272	15753	2600	1388	2.51	1480	3.25	1566	3.99	1650	4.75	1729	5.52	1807	6.34	1896	7.25	1975	8.15	2060	9.12	2129	10.00	2300	12.40		
9985	16965	2800	1480	3.00	1564	3.79	1650	4.60	1725	5.40	1800	6.21	1880	7.10	1955	8.00	2031	8.93	2107	9.91	2185	10.92	2335	13.02		
10698	18176	3000	1570	3.55	1657	4.43	1730	5.25	1808	6.12	1880	7.00	1951	7.90	2020	8.82	2089	9.78	2160	10.70	2229	11.70	2377	14.01		
11411	19387	3200	1667	4.20	1745	5.12	1820	6.05	1890	6.93	1960	7.85	2021	8.75	2090	9.74	2158	10.71	2219	11.70	2290	12.81	2420	15.00		



UFDW-20

Diámetro de la Turbina = 20 7/16"
 Área de Descarga = 4.289 ft²
 Rpm Max = Clase I 1900 Clase II 2400
 Velocidad Tangencial (FPM) = 5.350 x Rpm
 Max. BHP = 1.704 (Rpm/1000)³
 Peso Aprox. (Sin Motor) = 124 Kg (273Lb)

Wheel Diameter = 20 7/16"
 Discharge Area = 4.289 ft²
 Rpm Max = Clase I 1900 Clase II 2400
 Tip Speed (FPM) = 5.350 x Rpm
 Max. BHP = 1.704 (Rpm/1000)³
 Approx. Ship WT. (Less Motor) = 124 Kg (273Lb)

Caudal (Airflow)		Vel.	Presión Estática en Pulgadas C.A. (Static Pressure in Inches W. G.)																							
CFM	m ³ /HR		0.50"		1.00"		1.50"		2.00"		2.50"		3.00"		3.50"		4.00"		4.50"		5.00"		6.00"			
		FPM	Rpm	BHP	Rpm	BHP	Rpm	BHP	Rpm	BHP	Rpm	BHP	Rpm	BHP	Rpm	BHP	Rpm	BHP	Rpm	BHP	Rpm	BHP	Rpm	BHP		
3431	5829	800	616	0.38	835	0.82	1020	1.36	1180	1.95	1318	2.62	1445	3.30	1561	4.05	1670	4.84	1770	5.67	1870	6.56	2050	8.42		
4289	7287	1000	660	0.49	850	0.95	1023	1.53	1178	2.18	1310	2.85	1443	3.62	1560	4.41	1661	5.22	1768	6.11	1865	7.03	2040	8.95		
5147	8745	1200	720	0.63	881	1.13	1037	1.73	1179	2.38	1314	3.11	1441	3.92	1560	4.78	1659	5.62	1765	6.55	1862	7.52	2041	9.56		
6005	10202	1400	791	0.82	930	1.35	1066	1.97	1200	2.68	1325	3.44	1447	4.28	1555	5.16	1659	6.05	1765	7.05	1861	8.05	2040	10.30		
6862	11659	1600	865	1.05	987	1.62	1108	2.27	1225	3.00	1345	3.80	1460	4.67	1566	5.58	1670	6.55	1765	7.55	1860	8.60	2037	10.80		
7720	13116	1800	941	1.33	1050	1.95	1160	2.64	1268	3.40	1370	4.19	1475	5.10	1580	6.05	1676	7.03	1770	8.05	1865	9.17	2038	11.50		
8578	14574	2000	1017	1.65	1120	2.33	1215	3.05	1313	3.83	1410	4.67	1512	5.62	1607	6.59	1695	7.60	1785	8.66	1875	9.80	2048	12.30		
9436	16032	2200	1103	2.05	1200	2.80	1285	3.57	1370	4.36	1460	5.25	1550	6.20	1640	7.21	1722	8.23	1810	9.35	1889	10.50	2051	12.80		
10294	17490	2400	1179	2.48	1270	3.30	1355	4.15	1435	5.00	1520	5.93	1600	6.89	1680	7.90	1761	8.98	1840	10.15	1916	11.20	2075	13.80		
11151	18946	2600	1267	3.02	1350	3.90	1430	4.78	1508	5.71	1580	6.65	1657	7.68	1732	8.72	1800	9.79	1875	10.80	1950	12.10	2095	14.80		
12009	20403	2800	1350	3.60	1430	4.58	1503	5.51	1578	6.49	1645	7.48	1714	8.51	1780	9.60	1850	10.60	1923	11.91	1990	13.10	2130	15.75		
12867	21861	3000	1429	4.25	1510	5.32	1580	6.33	1651	7.37	1715	8.40	1780	9.50	1842	10.59	1910	11.81	1970	13.00	2040	14.22	2170	16.90		
13725	23319	3200	1525	5.06	1590	6.15	1660	7.25	1721	8.31	1790	9.45	1850	10.70	1910	11.71	1975	12.92	2030	14.21	2090	15.42	2215	18.11		

UFDW-22

Diámetro de la Turbina = 22 9/16"
 Área de Descarga = 5.256 ft²
 Rpm Max = Clase I 1700 Clase II 2100
 Velocidad Tangencial (FPM) = 5.907 x Rpm
 Max. BHP = 2.626 (Rpm/1000)³
 Peso Aprox. (Sin Motor) = 165Kg (363Lb)

Wheel Diameter = 22 9/16"
 Discharge Area = 5.256 ft²
 Max. Rpm = Class I 1700 Class II 2100
 Tip Speed (FPM) = 5.907 x Rpm
 Max. BHP = 2.626 (Rpm/1000)³
 Approx. Ship WT. (Less Motor) = 165Kg (363Lb)

Caudal (Airflow)		Vel.	Presión Estática en Pulgadas C.A. (Static Pressure in Inches W. G.)																							
CFM	m ³ /HR		0.50"		1.00"		1.50"		2.00"		2.50"		3.00"		3.50"		4.00"		4.50"		5.00"		6.00"			
		FPM	Rpm	BHP	Rpm	BHP	Rpm	BHP	Rpm	BHP	Rpm	BHP	Rpm	BHP	Rpm	BHP	Rpm	BHP	Rpm	BHP	Rpm	BHP	Rpm	BHP		
4205	7144	800	568	0.48	760	1.04	925	1.70	1071	2.47	1200	3.28	1315	4.16	1424	5.09	1520	6.05	1610	7.05	1700	8.10	1866	10.20		
5256	8930	1000	618	0.62	775	1.20	930	1.92	1065	2.71	1196	3.62	1311	4.57	1415	5.54	1517	6.60	1609	7.67	1698	8.81	1863	11.22		
6307	10716	1200	677	0.81	815	1.44	950	2.19	1075	3.03	1193	3.94	1305	4.94	1410	6.01	1512	7.14	1605	8.30	1690	9.50	1860	12.02		
7358	12501	1400	739	1.05	860	1.71	980	2.48	1100	3.38	1204	4.31	1315	5.39	1415	6.50	1512	7.68	1600	8.90	1690	10.22	1849	12.80		
8410	14289	1600	815	1.34	925	2.09	1030	2.90	1127	3.78	1230	4.80	1331	5.89	1425	7.03	1516	8.25	1607	9.53	1690	10.81	1850	13.66		
9461	16074	1800	890	1.75	989	2.53	1078	3.37	1175	4.30	1268	5.35	1360	6.46	1440	7.60	1530	8.88	1615	10.23	1698	11.60	1851	14.40		
10512	17860	2000	966	2.20	1055	3.05	1140	3.95	1228	4.92	1312	6.00	1390	7.10	1475	8.31	1555	9.62	1630	10.91	1711	12.34	1860	15.37		
11563	19646	2200	1040	2.71	1130	3.66	1210	4.63	1285	5.63	1359	6.73	1440	7.92	1510	9.15	1587	10.42	1660	11.80	1730	13.20	1870	16.28		
12614	21431	2400	1125	3.34	1200	4.33	1274	5.36	1350	6.48	1420	7.61	1490	8.82	1558	10.11	1628	11.42	1695	12.81	1760	14.30	1897	17.31		
13666	23219	2600	1202	4.04	1275	5.13	1349	6.25	1412	7.39	1480	8.60	1543	9.82	1610	11.11	1675	12.51	1740	13.90	1803	15.42	1925	18.59		
14717	25004	2800	1280	4.84	1350	6.03	1420	7.22	1485	8.45	1549	9.70	1608	11.00	1670	12.33	1725	13.80	1787	15.23	1845	16.74	1960	19.89		
15768	26790	3000	1357	5.70	1430	7.05	1496	8.33	1556	9.62	1615	10.92	1670	12.31	1730	13.73	1780	15.08	1840	16.60	1899	18.23	2006	21.41		
16819	28575	3200	1438	6.72	1511	8.20	1571	9.55	1628	10.90	1680	12.28	1740	13.72	1788	15.20	1845	16.71	1900	18.23	1950	19.80	2050	23.11		

UFDW-24

Diámetro de la Turbina = 26 5/8"
 Área de Descarga = 6.379 ft²
 Rpm Max = Clase I 1600 Clase II 1900
 Velocidad Tangencial (FPM) = 6.447 x Rpm
 Max. BHP = 4.270 (Rpm/1000)³
 Peso Aprox. (Sin Motor) = 190Kg (418Lb)

Wheel Diameter = 24 5/8"
 Discharge Area = 6.379 ft²
 Max. Rpm = Class I 1600 Class II 1900
 Tip Speed (FPM) = 6.447 x Rpm
 Max. BHP = 4.270 (Rpm/1000)³
 Approx. Ship WT. (Less Motor) = 190Kg (418Lb)

Caudal (Airflow)		Vel.	Presión Estática en Pulgadas C.A. (Static Pressure in Inches W. G.)																							
CFM	m ³ /HR		0.50"		1.00"		1.50"		2.00"		2.50"		3.00"		3.50"		4.00"		4.50"		5.00"		6.00"			
		FPM	Rpm	BHP	Rpm	BHP	Rpm	BHP	Rpm	BHP	Rpm	BHP	Rpm	BHP	Rpm	BHP	Rpm	BHP	Rpm	BHP	Rpm	BHP	Rpm	BHP		
5103	8670	800	515	0.58	690	1.25	840	2.07	969	2.97	1090	3.98	1195	5.04	1290	6.15	1378	7.32	1466	8.56	1550	9.85	1695	12.52		
6379	10838	1000	560	0.75	707	1.47	846	2.33	970	3.31	1086	4.39	1190	5.52	1287	6.72	1375	7.98	1463	9.33	1540	10.71	1691	13.59		
7655	13006	1200	616	0.99	740	1.74	859	2.62	980	3.67	1087	4.80	1189	6.02	1285	7.31	1370	8.64	1460	10.13	1538	11.51	1687	14.63		
8931	15174	1400	676	1.30	784	2.08	890	3.02	998	4.10	1100	5.27	1192	6.54	1285	7.90	1369	9.30	1455	10.81	1535	12.32	1683	15.52		
10206	17400	1600	745	1.67	840	2.55	936	3.52	1030	4.63	1120	5.81	1205	7.10	1291	8.52	1377	10.00	1456	11.50	1536	13.12	1681	16.52		
11482	19508	1800	810	2.12	900	3.08	985	4.12	1066	5.24	1150	6.49	1230	7.81	1313	9.27	1390	10.80	1467	12.42	1541	14.03	1680	17.50		
12758	21676	2000	880	2.68	960	3.69	1040	4.82	1115	6.00	1189	7.26	1266	8.65	1340	10.13	1415	11.73	1481	13.32	1550	15.00	1688	18.62		
14034	23844	2200	950	3.33	1024	4.44	1100	5.64	1170	6.89	1240	8.21	1305	9.60	1376	11.13	1440	12.70	1510	14.33	1575	16.11	1700	19.71		
15310	26012	2400	1022	4.07	1095	5.31	1160	6.55	1230	7.90	1290	9.25	1355	10.71	1415	12.30	1480	13.93	1543	15.61	1600	17.29	1720	21.10		
16585	28178	2600	1095	4.95	1160	6.27	1227	7.63	1290	9.02	1348	10.50	1406	12.01	1465	13.62	1520	15.20	1580	16.93	1640	18.72	1751	22.52		
17861	30346	2800	1168	5.92	1230	7.37	1295	8.84	1351	10.31	1405	11.81	1459	13.39	1516	15.00	1570	16.69	1625	18.51	1680	20.34	1786	24.22		
19137	32514	3000	1236	6.98	1300	8.61	1360	10.20	1418	11.73	1470	13.31	1520	15.00	1569	16.69	1622	18.41	1675	20.23	1723	22.11	1820	26.00		
20413	34682	3200	1311	8.25	1377	10.00	1430	11.73	1480	13.31	1533	15.01	1579	16.69	1630	18.50	1680	20.33	1726	22.11	1775	24.13	1870	28.11		

UFDW

Curvas de operación / Performance curves



UFDW-10

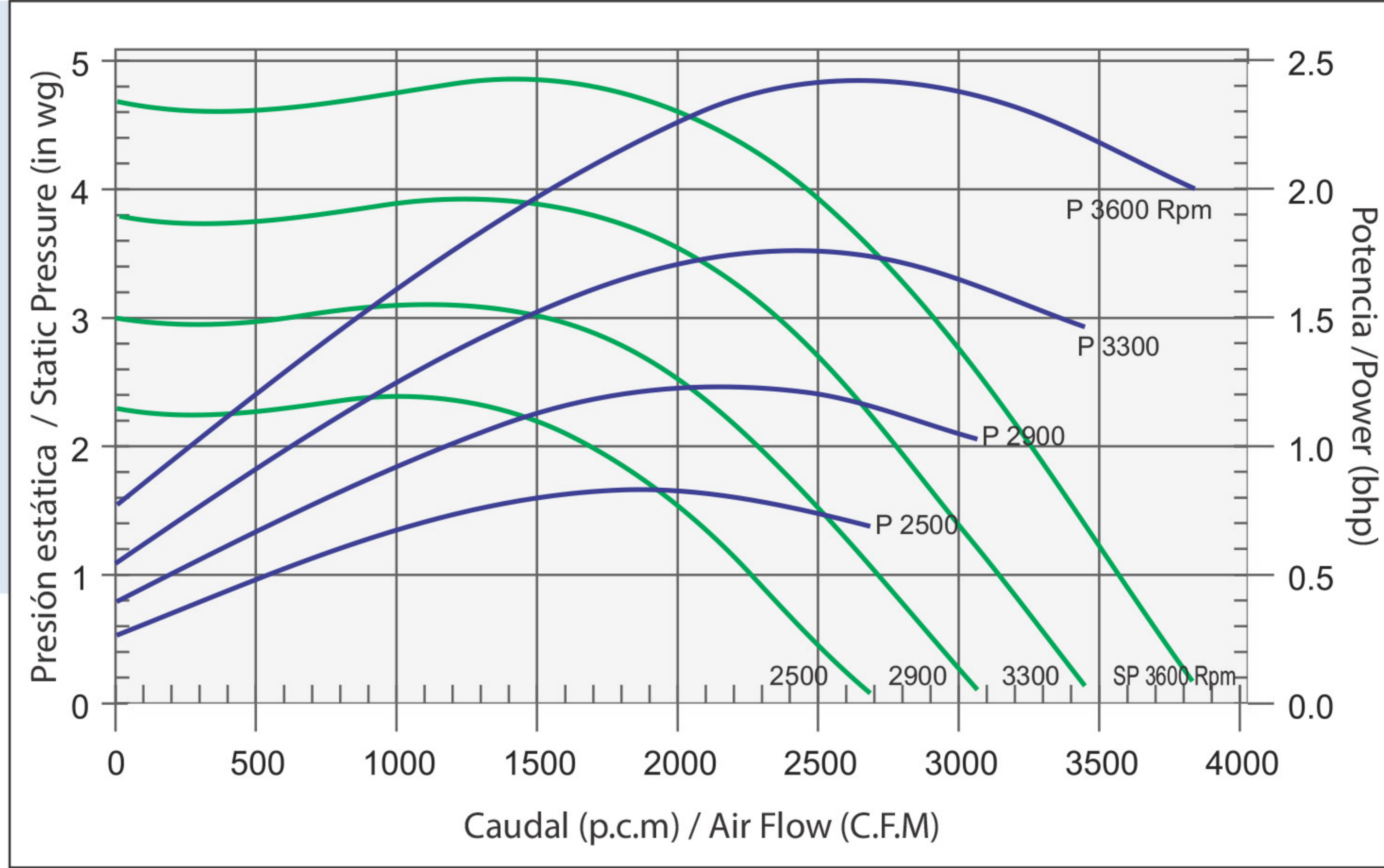

UFDW-12

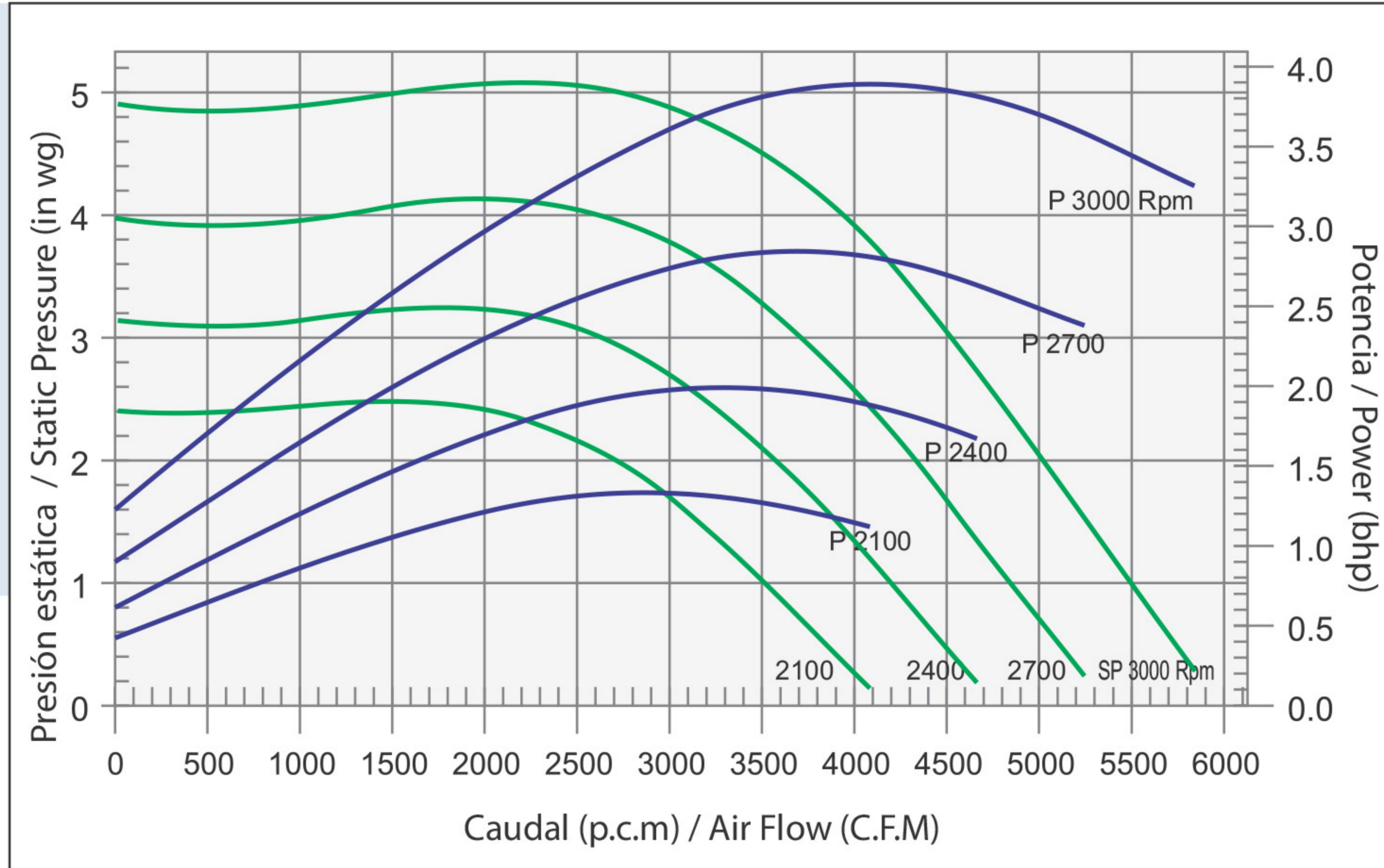

UFDW-13

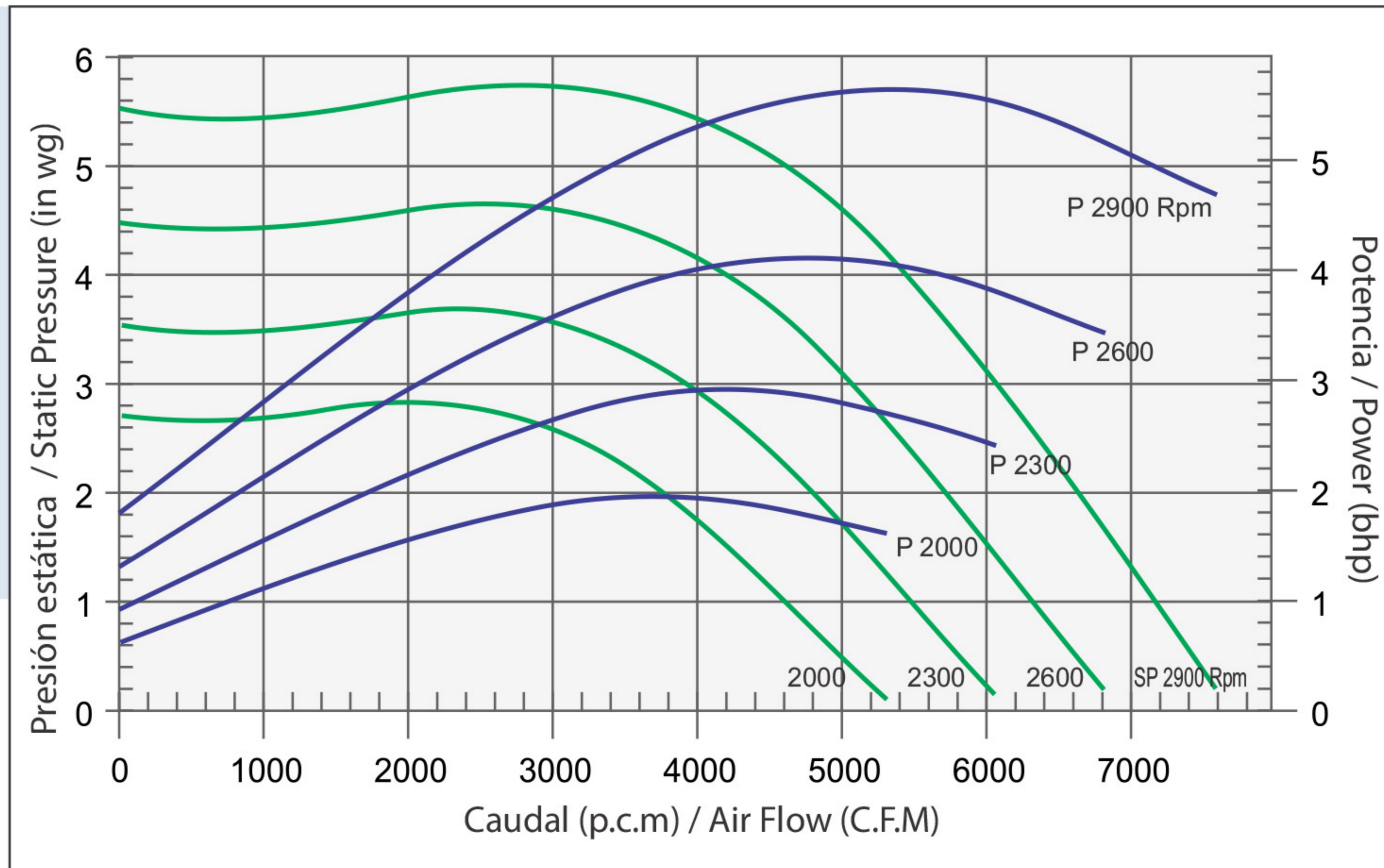

Todas las capacidades están basadas en la Densidad Estándar de Aire de 0.075 Lb/ft³ @ 70°F y 0 pies de Elevación: 1.2 kg/m³ @ 21°C y 0 mt
 (All Capacities are based on Standard Air Density of 0.075 Lb/ft³ @ 70°F and 0 Ft elevation: 1.2 kg/m³ @ 21°C and 0 mt)



UFDW-15

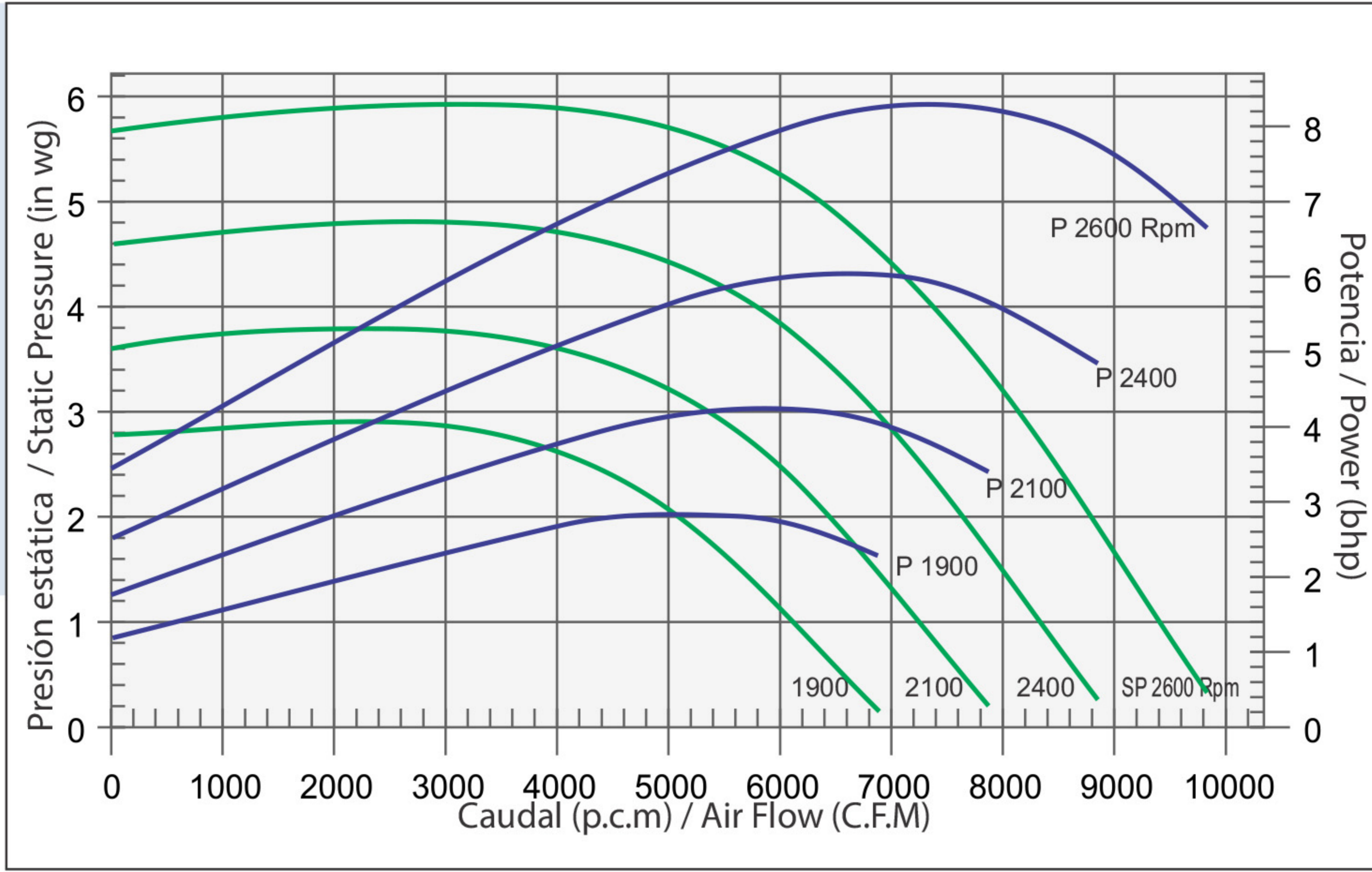

UFDW-16

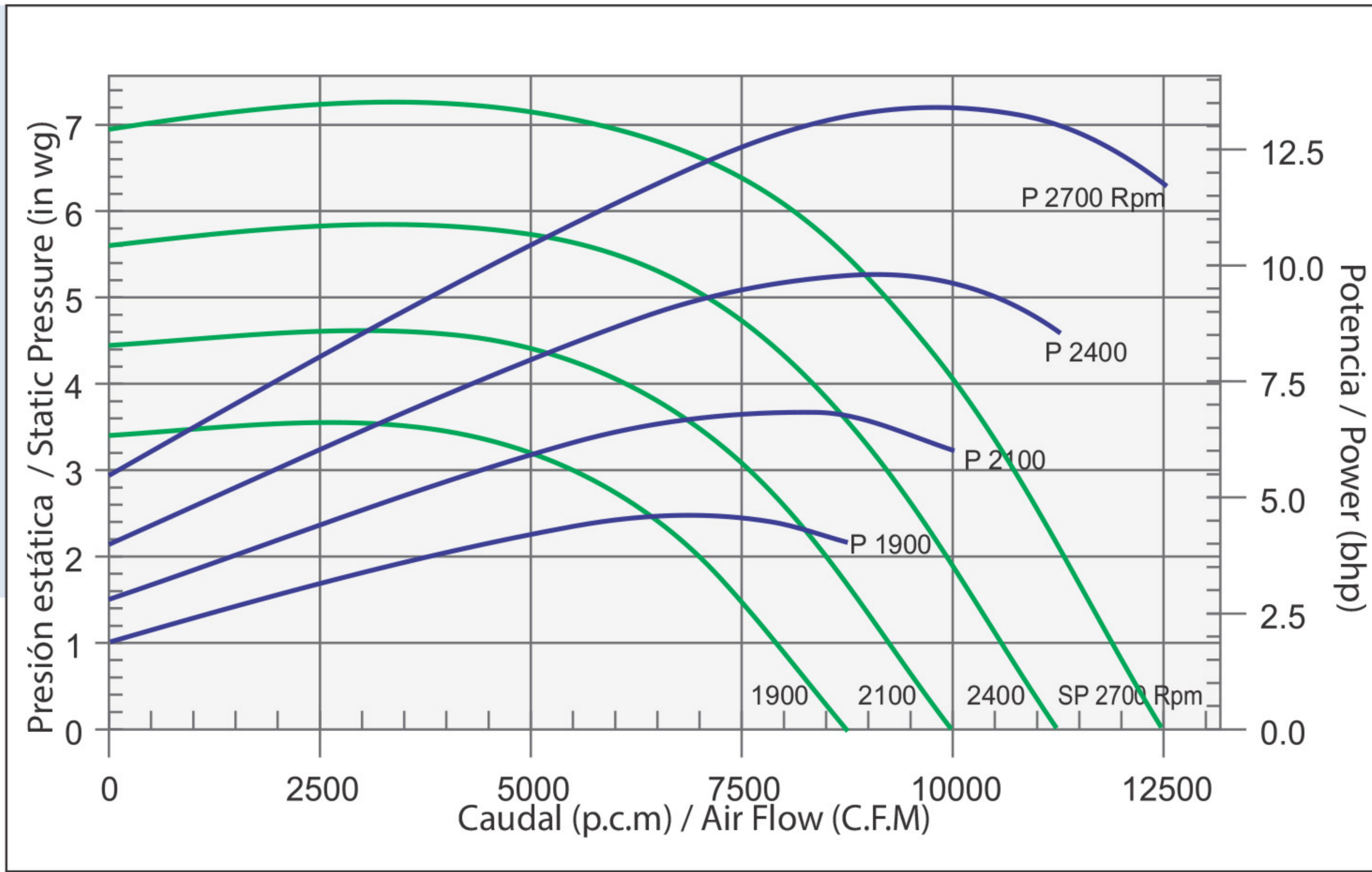

UFDW-18

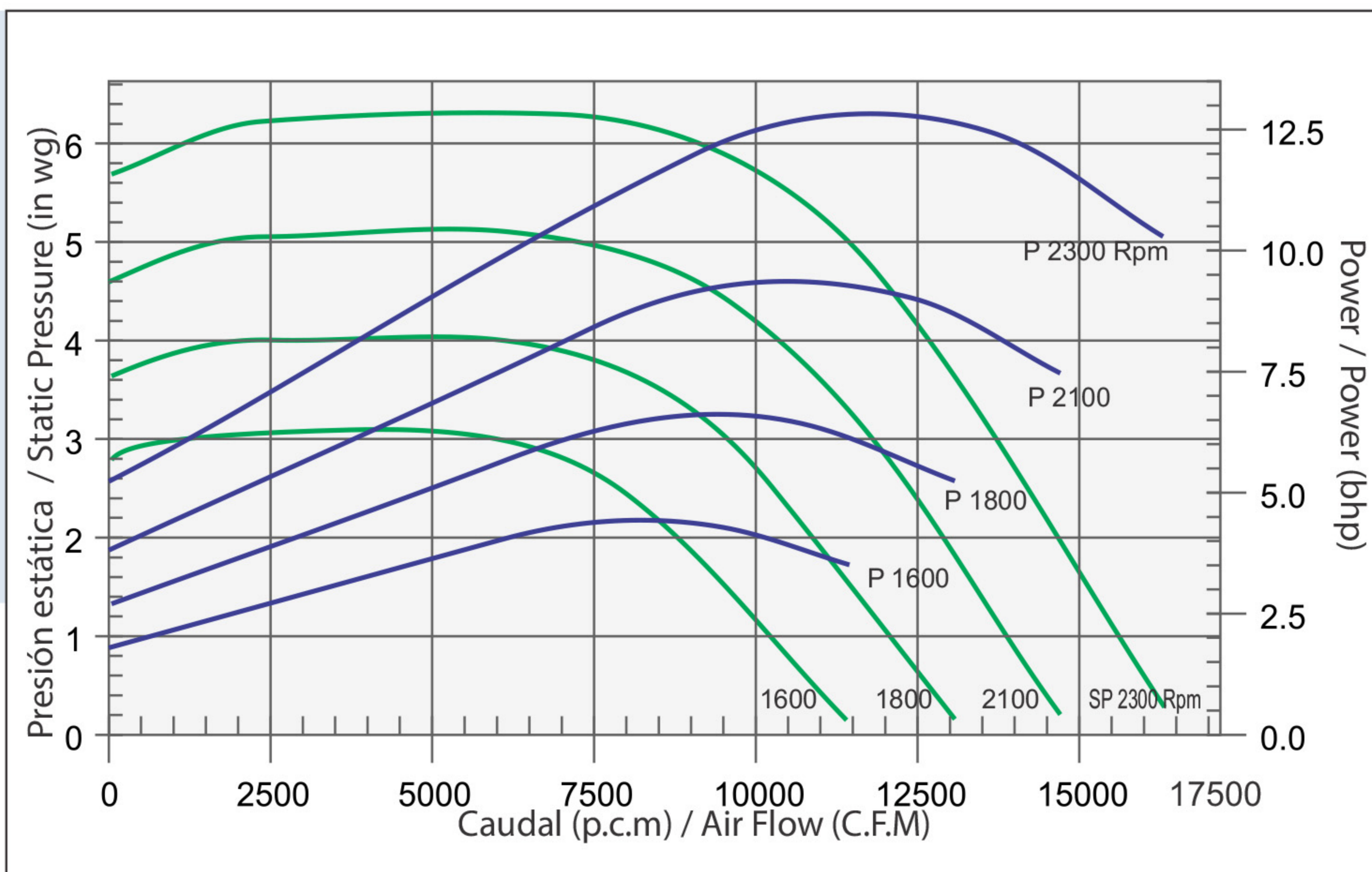

Todas las capacidades están basadas en la Densidad Estándar de Aire de 0.075 Lb/ft³ @ 70°F y 0 pies de Elevación: 1.2 kg/m³ @ 21°C y 0 mt
 (All Capacities are based on Standard Air Density of 0.075 Lb/ft³ @ 70°F and 0 Ft elevation: 1.2 kg/m³ @ 21°C and 0 mt)



UFDW-20

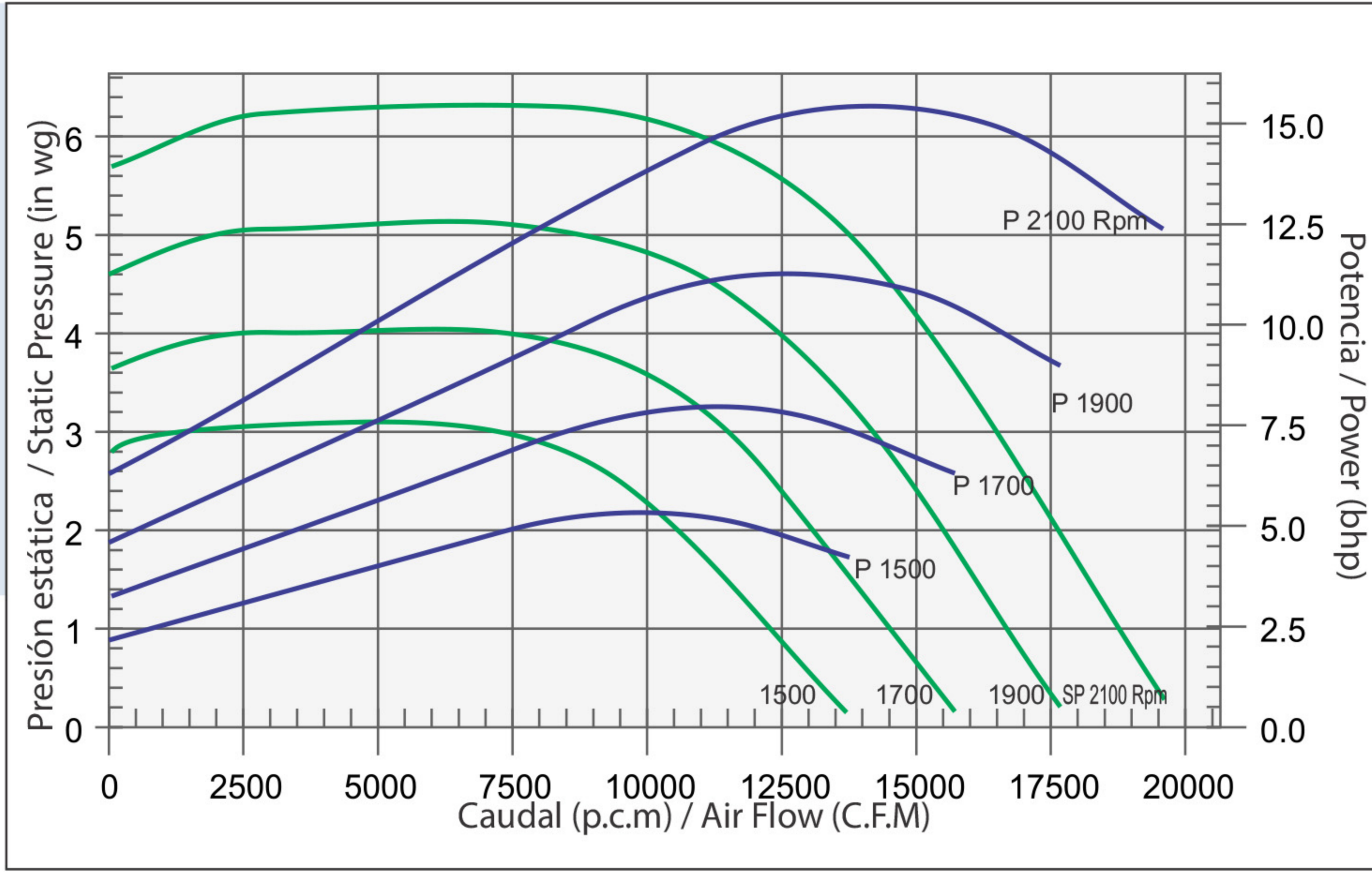

UFDW-22

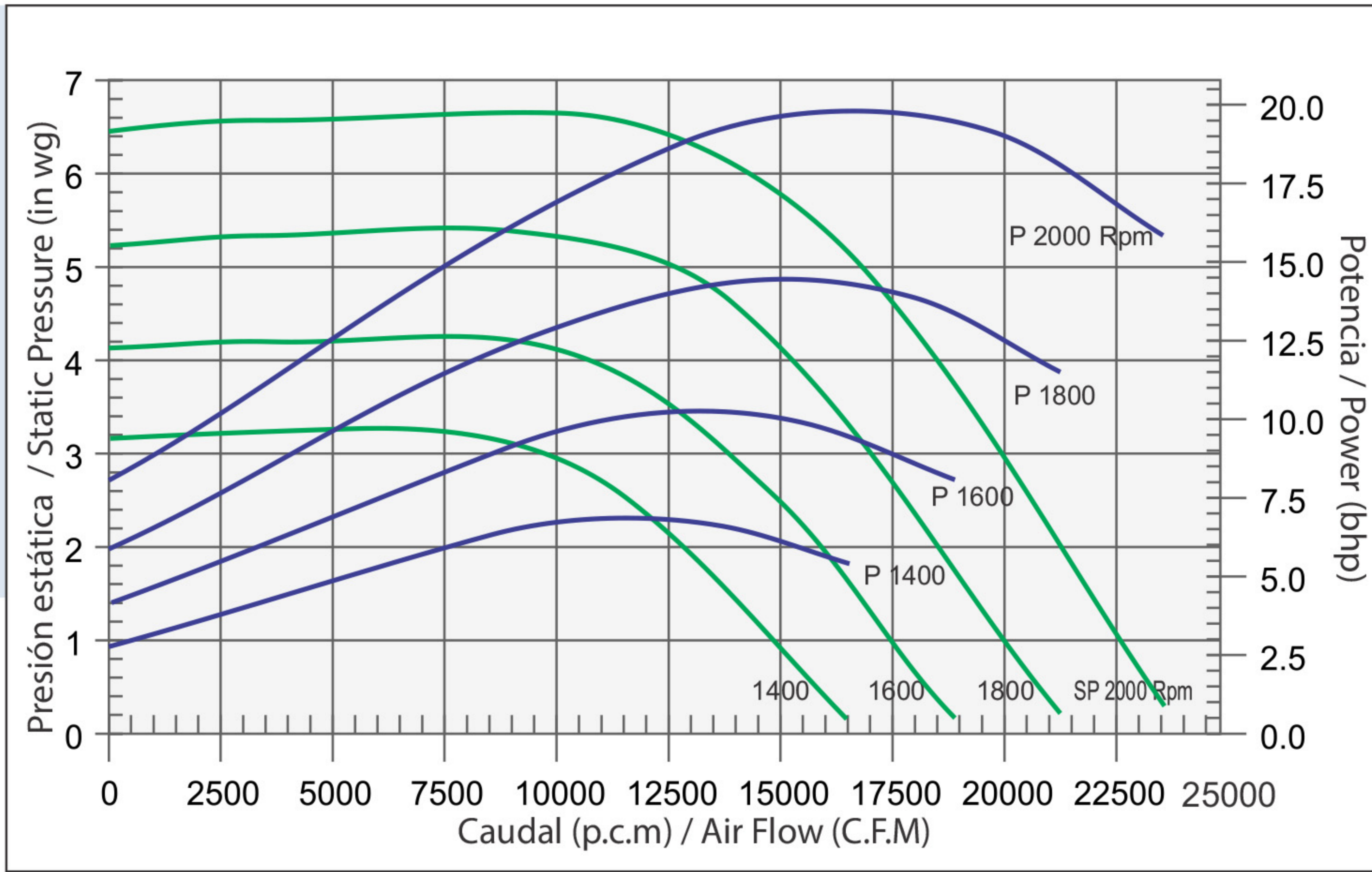

UFDW-24

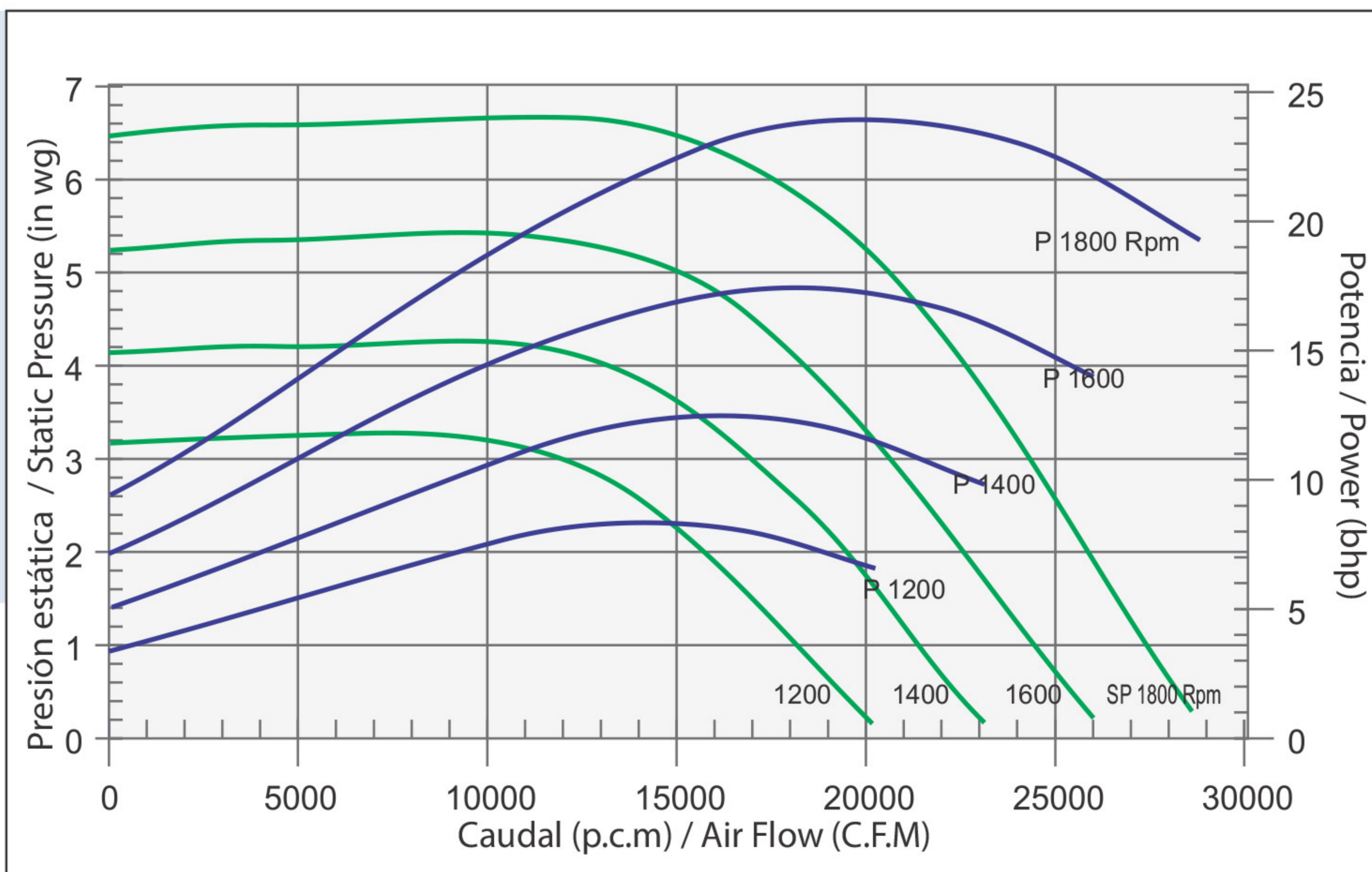

Todas las capacidades están basadas en la Densidad Estándar de Aire de 0.075 Lb/ft³ @ 70°F y 0 pies de Elevación: 1.2 kg/m³ @ 21°C y 0 mt
 (All Capacities are based on Standard Air Density of 0.075 Lb/ft³ @ 70°F and 0 Ft elevation: 1.2 kg/m³ @ 21°C and 0 mt)



Vista frontal
Front view

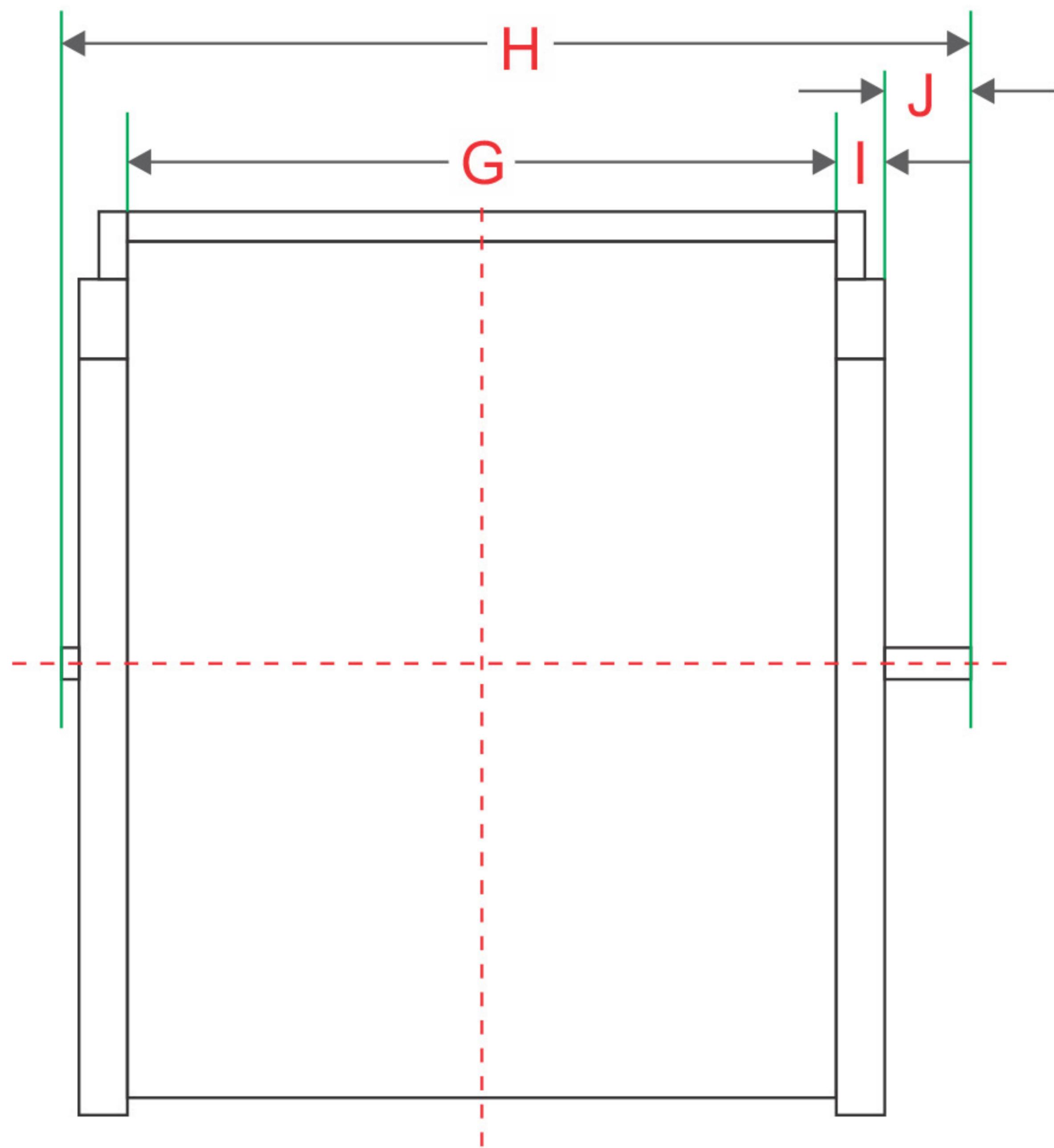

Vista lateral
Side view

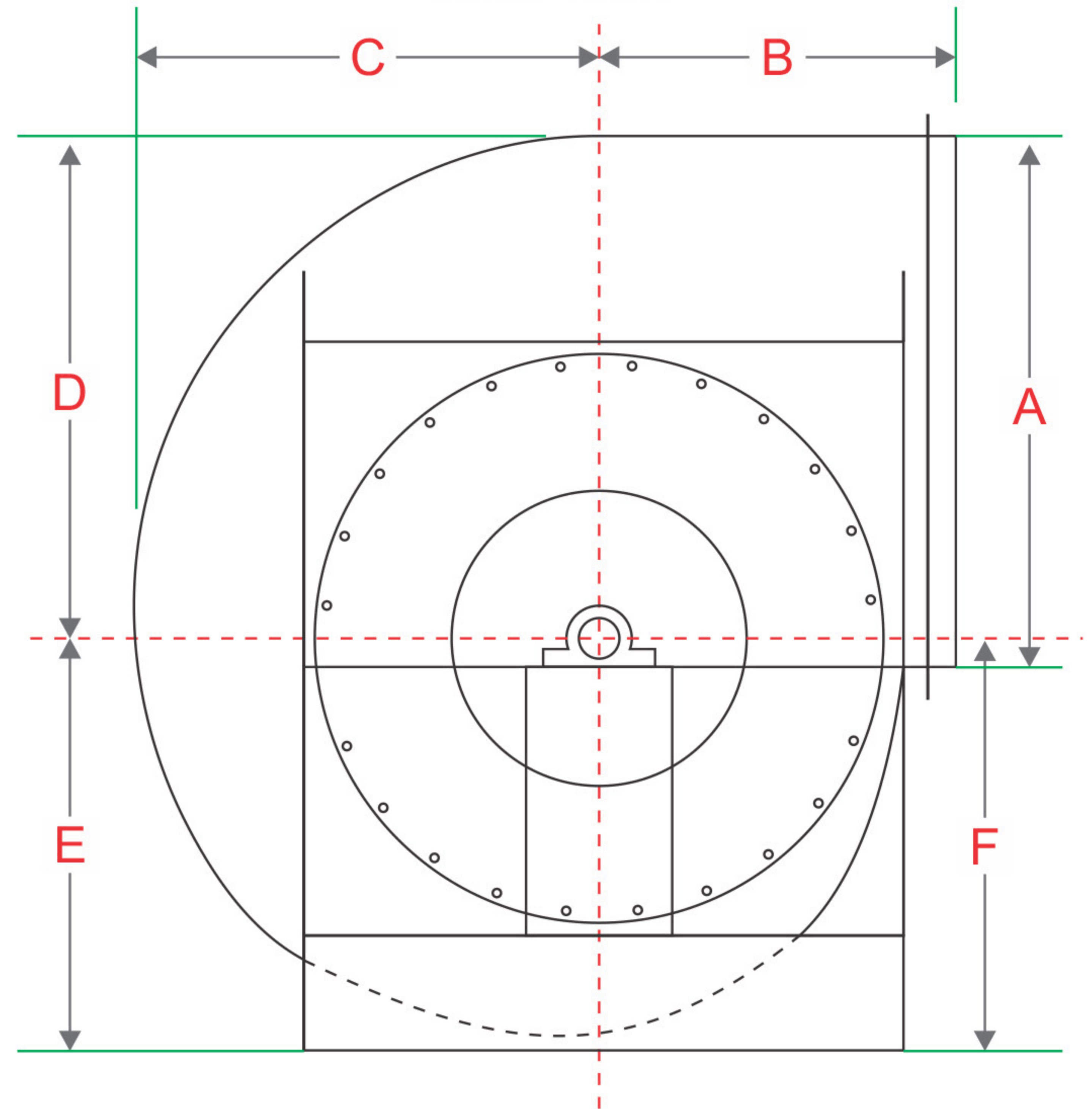

Opción brida en descarga
Flanged outlet option

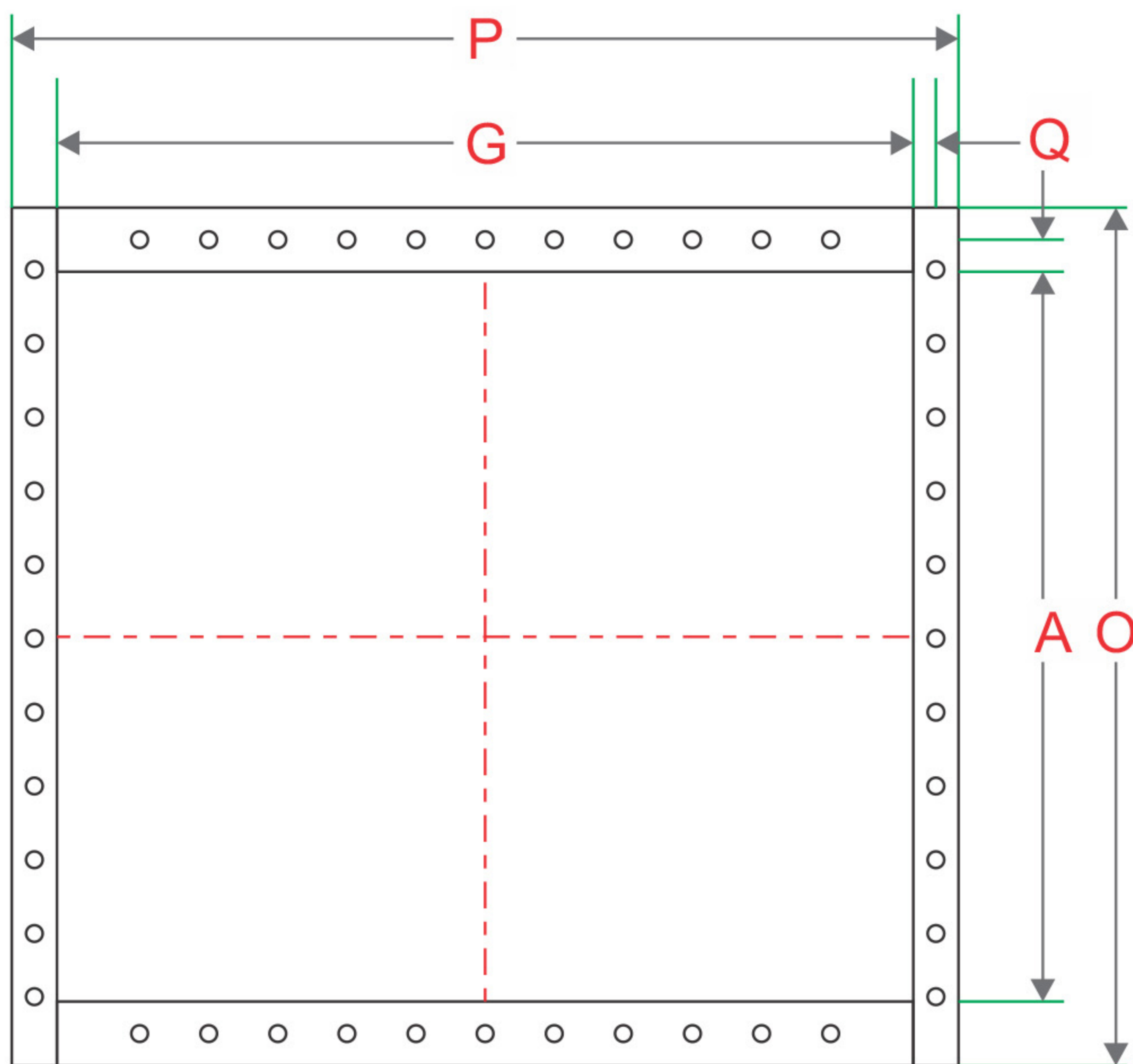

Vista planta para barrenos
Foundation plan

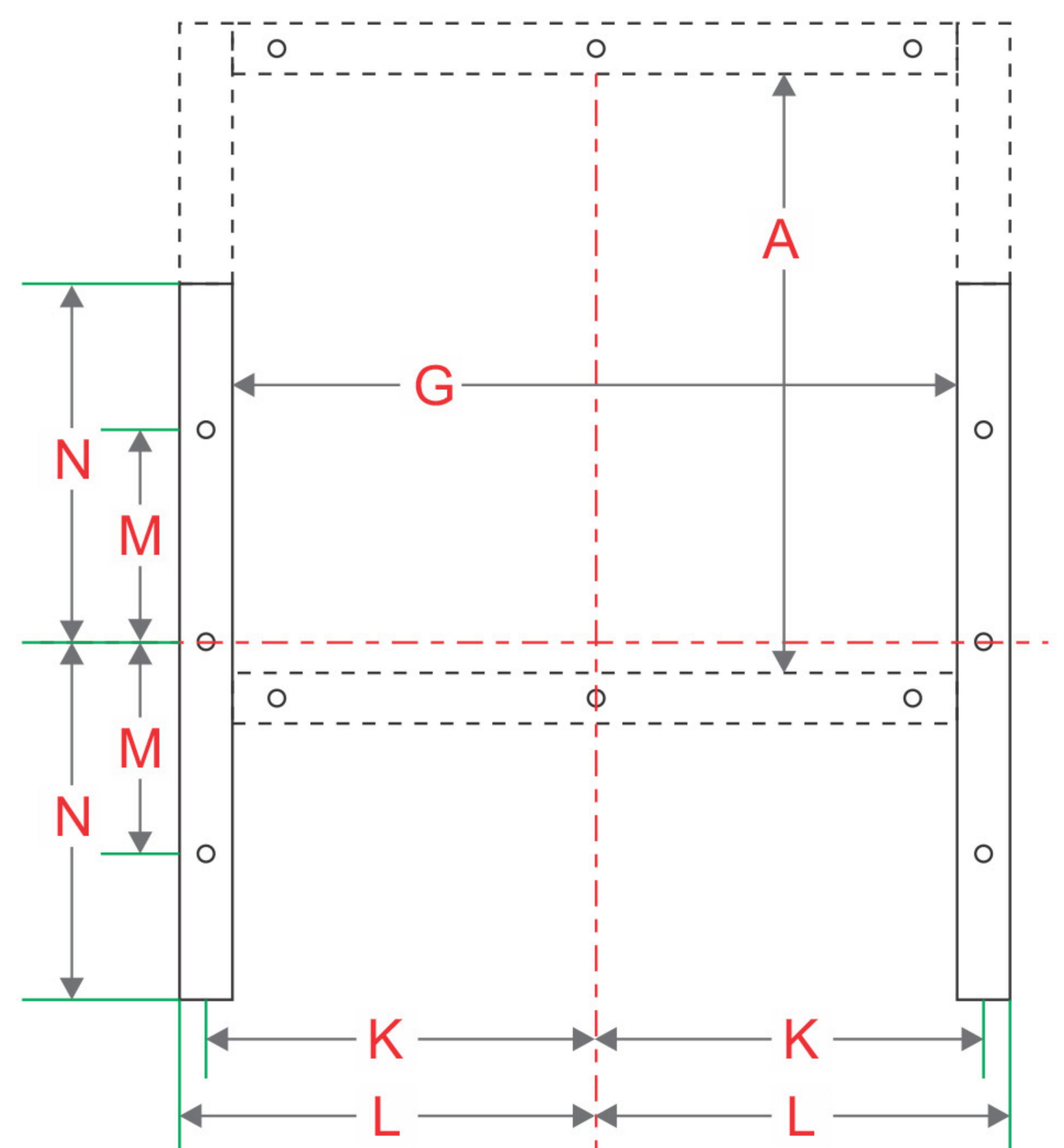

UFDW

Dimensiones generales / Dimensions



Modelo Model		Pulgadas (Inches)																	Perforaciones Base		Perforaciones Brida	
		A	B	C	D	E	F	G	H	I	J	K	L	M	N	O	P	Q	Ø	Ø	Ø	Ø
																			Base Holes	Flange Holes		
UFDW-10	11 1/4	8 1/2	10 1/8	10 5/8	11 1/4	8 1/2	13 5/8	21 1/4	2 1/4	3	7 7/8	8 3/4	4 5/8	6 5/8	13 1/4	15 5/8	5/8	9/16	5/16			
UFDW-12	13 5/8	10	12 3/8	13	13 3/4	10 3/8	16 5/8	24 1/4	2 1/4	3	9 3/8	10 1/4	5 7/8	8	15 5/8	18 5/8	5/8	9/16	5/16			
UFDW-13	15 1/4	11	13 5/8	14 1/4	15	11 3/8	18 3/4	26 3/8	2 1/4	3	10 3/4	11 5/8	6 5/8	8 3/4	17 1/4	20 3/4	5/8	9/16	5/16			
UFDW-15	16 7/8	12	15 1/8	15 7/8	16 3/4	12 5/8	20 1/4	28 3/8	2 1/4	3 1/2	11 1/2	12 3/8	7 1/2	9 5/8	18 7/8	22 1/4	5/8	9/16	5/16			
UFDW-16	18 5/8	13	16 5/8	17 1/2	18 1/2	14	22 1/4	30 3/8	2 1/4	3 1/2	12 1/2	13 3/8	8 1/2	10 5/8	21 1/8	24 3/4	3/4	9/16	7/16			
UFDW-18	20 3/4	14	18 1/2	19 3/8	20 1/4	15 1/2	24 3/4	33 7/8	2 3/4	3 1/2	14	15 1/8	9 3/8	11 5/8	23 1/4	27 1/4	3/4	9/16	7/16			
UFDW-20	22 7/8	15 1/2	20 3/8	21 3/8	22 1/4	17	27	36 5/8	2 3/4	4	15 1/8	16 1/4	10 3/8	12 7/8	25 3/8	29 1/2	3/4	9/16	7/16			
UFDW-22	25 1/8	17	22 1/2	23 5/8	24 1/2	18 7/8	30 1/8	39 3/4	2 3/4	4	16 3/4	17 7/8	10 7/8	13 7/8	27 5/8	32 5/8	3/4	9/16	7/16			
UFDW-24	27 5/8	19	24 3/4	26	26 3/4	20 3/4	33 1/4	42 7/8	2 3/4	4	18 1/4	19 3/8	12 1/4	15 1/2	30 5/8	36 1/4	7/8	9/16	7/16			



OFICINAS:
Cerrada José Rivera No. 3
Col. Colinas del Bosque, Corregidora Querétaro

CONTACTO:
442 721 34 12
442 106 35 73 - Vía Whatsapp
lidia@dasseringenieria.com
equiposindustriales@dasseringenieria.com
contacto@dasseringenieria.com