



**KCB
KCD
KCBR**



Aero ventiladores tubulares centrifugos en línea ATC
ATC In Line tubular centrifugal fans



The Right Choice



KCB/KCD/KCBR

Indice

Aplicaciones	1
Factores de corrección	3
Especificaciones técnicas	5
Tipos de montaje	14
Dimensiones generales	15

Table of Contents

Applications	2
Correction factors	3
Performance data	5
Mounting configurations	14
Dimensions	15

KCB/KCD/KCBR

AERO VENTILADORES

TUBULARES

CENTRIFUGOS EN LINEA ATC



La serie KC de los Aero Ventiladores Tubulares Centrífugos en línea, marca ATC con opción por transmisión de poleas y banda (KCB) y por transmisión directa (KCD), ha sido especialmente diseñada para los sistemas de inyección y extracción de aire en aplicaciones comerciales e industriales; disponibles en 9 tamaños con diámetros de turbina desde 10 1/4" hasta 24 5/8" en distintas clases constructivas, rotaciones y diferentes posiciones de montaje, ofreciendo la gama de ventiladores más versátil, eficiente e ideal para instalaciones de espacios más reducidos.

Aplicaciones

Campanas de extracción de humo y grasa en restaurantes, sistemas de ductos para aire acondicionado, ventilación y calefacción, hospitales, hotelería, estacionamientos públicos, centros comerciales, industrias de aviación, automotiva, imprenta, minería, pintura, petróleo, textil, acero, etc.

Características principales

- Conjunto carcasa, cono de succión, soporte del motor y bridas fabricado en acero al carbón de diferentes calibres según tipo de clase del ventilador (I-II).
- Turbina centrífuga de alta eficiencia y operación silenciosa con alabes atrasados estática y dinámicamente balanceado, fabricada en acero al carbón, acero inoxidable ó aluminio según aplicaciones.
- El proceso de prepintado con tratamientos químicos y posteriormente la aplicación electrostática de pintura poliéster en polvo horneada altamente resistente a la corrosión e intemperie en todos los componentes de los ventiladores tubulares centrífugos es estándar.
- Disponible en 2 diferentes posiciones de descarga y construcción (horizontal, vertical), 2 distintos tipos de montaje (piso con tacones antivibratorios ó resortes con base; techo con resortes colgantes), 3 posiciones del motor para el montaje en piso (posición 0°, 90°, 270°), 4 posiciones del motor para el montaje en techo (posición 0°, 90°, 180°, 270°) y 2 diferentes rotaciones del rotor (CW – CCW).

- Chumaceras o Rodamientos de alta eficiencia y mínimo mantenimiento, diseñados para aplicaciones de servicio pesado adquiridos de los fabricantes mundialmente reconocidos.
- Flechas o ejes impulsores seleccionados en diferentes diámetros y longitudes según tamaño y clase del ventilador, fabricados en acero AISI C-1045, perfectamente pulidos y rectificadas en toda su longitud y protegidos con un recubrimiento anticorrosivo.
- Base ajustable de motor fabricada en acero al carbón y diseñada para ajuste, alineación y tensión de las bandas con una precisión y rapidez.
- Accionado por transmisión de poleas y bandas (KCB), y por transmisión directa (KCD) a los motores eléctricos de alta eficiencia diseñados bajo especificaciones NEMA, permitiendo lograr las distintas relaciones de caudal y presión.
- Construcción anti-chispa según clasificaciones de AMCA.
 - Tipo A - Todos los componentes del ventilador en contacto con aire o gas deben ser contruidos de material no ferroso.
 - Tipo B - Turbina y cubierta para chumaceras colocado dentro de la carcasa del ventilador por donde pasa la flecha deben ser contruidos de material no ferroso.
 - Tipo C – El ventilador debe ser contruido de tal forma, evitando cualquier contacto o fricción entre 2 partes ferrosos por un desplazamiento del rotor o flecha.

Accesorios Disponibles

- Registro o Puerta de Inspección.
- Tubo de dren.
- Tacones o resortes antivibratorios.
- Malla de protección en succión o descarga.
- Construcción anti-chispa.
- Cubierta para motor.
- Base o Soporte del ventilador para montaje.
- Cubrebandas.
- Contrabridas para ducto en succión ó descarga.
- Sello de flecha.
- Conector flexible de lona.
- Graseras extendidas.
- Interruptor.
- Recubrimientos especiales para aplicaciones de alta resistencia a la corrosión o temperatura

Nomenclatura:

KC B - 15 - CW - I

1 2 3 4 5

1. Modelo del Ventilador.
2. Tipo de Trasmisión.
 - I. Poleas y Bandas (B)
 - II. Directo (D)
3. Tamaño de Ventilador

4. Rotación de la Turbina:
 - CW - Sentido Reloj
 - CCW - Sentido contra Reloj
5. Clase Constructiva del Ventilador
 - I – Clase I
 - II – Clase II



KCB/KCD/KCBR

AERO VENTILADORES
TUBULARES
CENTRIFUGOS EN LINEA ATC

The KC series are heavy duty tubular centrifugal supply and exhaust fans designed for class I and II performance with reliable air movement in commercial and industrial applications. ATC centrifugal in line fans are available in 9 sizes with wheel diameters from 10 1/4" through 24 5/8", different performance classes, rotations, discharge and mounting positions, offering the line of most versatile, quiet, energy efficient and space saving fans which can handle a wide range of air volumen and pressure in the global market.

Applications

Hood exhaust in restaurants, HVAC systems, hospitals, hotels, underground parking lots, commercial centers, aviation, automotive, printing, mining, painting, petroleum, textile, steel industries, etc.

Construction Features

- Housings, inlet cones, drive stands, flanges, weather proof motor and drive cover are made of air tight heavy gauge all welded steel construction.
- Backward inclined non-overloading wheels are constructed with welded steel, stainless steel or aluminum, statically and dynamically balanced at the factory and designed for optimum performance for most operating conditions.
- Electrostatically applied powder coating is Standard on all ATC fans. For special requirements, please contact the factory.
- The fans are available in 2 different discharge and construction arrangements (Horizontal, Vertical), 2 distinct type of mounting positions (Floor mounted with rubber – in – shear or spring type isolators; ceiling mounted with spring type isolators), 3 motor positions for floor mounted (0°, 90°, 270°), 4 motor positions for ceiling mounted (0°, 90°, 180°, 270°) and clockwise (CW) or counter clockwise (CCW) wheel rotation.
- Self-aligning heavy duty, pillow block ball bearings are designed to operate under the most severe atmospheric conditions and are supplied by the most prestigious world wide manufacturers.

- Shafts are designed for long life in different diameters and lengths, turned, ground and polished of solid SAE 1045 steel for smooth operation, key-wayed on each and are protected with a corrosion resistant coating.
- Adjustable steel motor plate pivoted at one end for ease of belt tensioning.
- The KC centrifugal series are the ideal choice for the general ventilation applications with the space saving advantages of an axial type fan in both belt drive (KCB) and direct drive (KCD) design.
- AMCA classifications for spark resistant construction where hazardous, explosive or flammable conditions exist.
 - Type A- All parts of the fan in contact with the air or gas being handled shall be made of non-ferrous material.
 - Type B- The fan shall have a non-ferrous bearing cover and wheel about the opening through which shaft passes. Ferrous hubs, shafts and hardware are permitted.
 - Type C- The fan shall be so constructed that a shift of the wheel or shaft will not permit two ferrous parts of the fan to rub or strike. Fans for this condition will be furnished with a nonferrous inlet cone and bearing cover around the shaft opening.

Optional Accessories

- Access or clean-out doors.
- Drains.
- Vibration Isolators.
- Inlet and outlet screens.
- Spark resistant construction.
- Motor cover
- Mounting or support legs.
- Belt guard.
- Companion flanges for duct connection.
- Shaft seal.
- Flexible joint.
- Copper lube lines for greasing.
- Disconnect switch.
- Special protective coating for corrosion and high temperature.

Nomenclature:

KC B - 15 - CW - I
1 2 3 4 5

1. Fan Model.
2. Drive Type.
I. Belt Drive (B) II. Direct Drive (D)
3. Fan Size.

4. Impeller Rotation.
CW – Clockwise CCW – Counter Clockwise
5. Fan Class.
I. Class I II. Class II

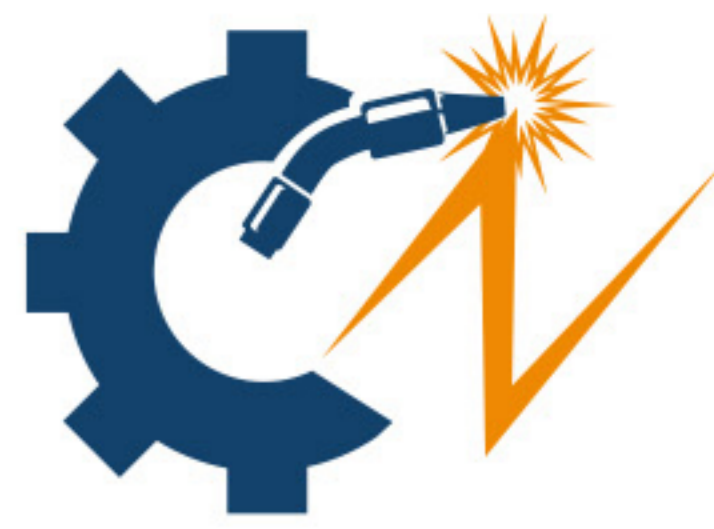

Factores de Corrección de Densidad del Aire por Altitud y Temperatura

Los Valores presentados en las Tablas de Selección se refieren a las Condiciones Estándar de Operación (0 Metros ó 0 pies sobre nivel del mar, 21°C ó 70°F, 760 mm Hg. ó 29.92 In. Hg.). Para condiciones distintas de operación es necesario aplicar factores de corrección según las siguientes tablas:

Air Density Ratios at various Altitudes and Air Temperatures

The Values which are shown in the tables of performance Data refer to Standard Operation Conditions (0 meters or 0 feet above sea level, 21°C ó 70°F, 760 mm Hg. or 29.92 In. Hg.). Apply the following correction factors for other operation conditions not standard.

AIR GAS	Altitud en pies sobre el nivel del mar correspondiente a la Presión Barométrica en Pulgadas Hg. (Altitude In Feet Above Sea Level With Corresponding Barometric Pressure in Inches Hg.)										
TEMP °F	0 29.92	1000 28.86	2000 27.82	3000 26.81	4000 25.84	5000 24.89	6000 23.98	7000 23.09	8000 22.22	9000 21.38	10000 20.58
-20	0.83	0.86	0.89	0.93	0.96	1	1.04	1.08	1.12	1.16	1.21
0	0.87	0.91	0.94	0.97	1.01	1.04	1.08	1.13	1.17	1.22	1.26
50	0.96	1	1.04	1.07	1.11	1.16	1.2	1.25	1.3	1.35	1.4
70	1	1.04	1.08	1.12	1.16	1.2	1.25	1.3	1.35	1.4	1.45
100	1.06	1.1	1.14	1.18	1.22	1.27	1.32	1.37	1.42	1.48	1.54
150	1.15	1.19	1.24	1.3	1.33	1.38	1.44	1.49	1.55	1.61	1.67
200	1.25	1.29	1.34	1.39	1.44	1.5	1.56	1.61	1.68	1.75	1.81
250	1.34	1.39	1.44	1.5	1.55	1.61	1.67	1.74	1.8	1.88	1.95
300	1.44	1.49	1.54	1.6	1.66	1.72	1.79	1.86	1.93	2.01	2.08
350	1.53	1.59	1.65	1.71	1.77	1.84	1.91	1.98	2.06	2.14	2.22
400	1.62	1.68	1.75	1.81	1.88	1.95	2.03	2.1	2.18	2.27	2.36
450	1.72	1.78	1.85	1.92	1.99	2.07	2.15	2.23	2.31	2.4	2.49
500	1.81	1.88	1.95	2.02	2.1	2.18	2.26	2.35	2.44	2.54	2.63
550	1.91	1.98	2.05	2.13	2.2	2.29	2.38	2.47	2.56	2.67	2.77
600	2	2.08	2.15	2.23	2.32	2.4	2.5	2.59	2.69	2.84	2.91
650	2.1	2.17	2.25	2.34	2.43	2.52	2.62	2.72	2.83	2.93	3.05
700	2.19	2.27	2.35	2.44	2.53	2.63	2.73	2.83	2.94	3.07	3.18
800	2.38	2.46	2.55	2.65	2.75	2.86	2.97	3.08	3.2	3.32	3.45

AIR GAS	Altitud en metros sobre el nivel del mar correspondiente a la Presión Barométrica en mm Hg. (Altitude In Meters Above Sea Level With Corresponding Barometric Pressure in Millimeters Hg.)										
TEMP °C	0 760	250 738	500 717	750 697	1000 677	1250 657	1500 639	1750 620	2000 603	2500 569	3000 536
0	0.93	0.95	0.98	1.01	1.04	1.08	1.1	1.14	1.16	1.23	1.32
21	1	1.03	1.05	1.09	1.12	1.15	1.19	1.22	1.27	1.33	1.41
50	1.1	1.12	1.16	1.19	1.23	1.27	1.3	1.33	1.39	1.47	1.56
75	1.18	1.22	1.25	1.28	1.33	1.37	1.41	1.45	1.49	1.59	1.67
100	1.27	1.3	1.33	1.39	1.43	1.47	1.52	1.54	1.59	1.69	1.79
125	1.35	1.39	1.43	1.47	1.52	1.56	1.61	1.67	1.69	1.82	1.92
150	1.43	1.47	1.52	1.56	1.61	1.67	1.69	1.75	1.82	1.92	2.04
175	1.52	1.56	1.61	1.67	1.69	1.75	1.82	1.85	1.92	2.04	2.17
200	1.61	1.64	1.69	1.75	1.79	1.85	1.92	1.96	2.04	2.13	2.27
225	1.69	1.72	1.79	1.85	1.89	1.96	2	2.08	2.13	2.27	2.38
250	1.79	1.82	1.89	1.92	2	2.04	2.13	2.17	2.22	2.38	2.5
275	1.85	1.92	1.96	2.04	2.08	2.13	2.22	2.27	2.33	2.5	2.63
300	1.96	2	2.04	2.13	2.17	2.22	2.33	2.38	2.44	2.63	2.78
325	2.04	2.08	2.13	2.22	2.27	2.33	2.44	2.5	2.56	2.7	2.86
350	2.13	2.17	2.22	2.33	2.38	2.44	2.5	2.56	2.63	2.86	3.03
375	2.17	2.27	2.33	2.38	2.44	2.56	2.63	2.7	2.78	2.94	3.13
400	2.27	2.33	2.44	2.5	2.56	2.63	2.7	2.78	2.86	3.03	3.23
425	2.38	2.44	2.5	2.56	2.63	2.7	2.86	2.94	3.03	3.13	3.33
450	2.44	2.5	2.63	2.7	2.78	2.86	2.94	3.03	3.13	3.23	3.45
475	2.56	2.63	2.7	2.78	2.86	2.94	3.03	3.13	3.23	3.45	3.57



Factores de corrección de RPM por temperatura

Reduce la Máxima Velocidad Permitible del Ventilador (RPM) aplicando los Factores de Corrección según la siguiente tabla:

Temperature / RPM corrections

Reduce maximum allowable fan speed by applying RPM correction factors from the following table:

TEMP	-20°F - 150°F (-29°C- 66°C)	151°F - 300°F (66°C- 149°C)	301°F - 600°F (149°C-316°C)	601°F - 800°F (316°C-427°C)
FACTOR	1	0.957	0.88	0.79

Características Físicas / Physical data

MODELO	DIAMETRO TURBINA (IN)	PESO TURBINA (LBS) CLASE I	PESO TURBINA (LBS) CLASE II	Max RPM TURBINA CLASE I	Max RPM TURBINA CLASE II	Max RPM TURBINA CLASE III	Max ARMAZON MOTOR CLASE I	Max ARMAZON MOTOR CLASE II	DIAMETRO FLECHA (IN) CLASE I	DIAMETRO FLECHA (IN) CLASE II	PESO APROX VENTILADOR *(LBS)	
											CLASE I	CLASE II
MODEL	WHEEL DIAMETER (IN)	WHEEL WEIGHT (LBS) CLASS I	WHEEL WEIGHT (LBS) CLASS II	Max WHEEL RPM CLASS I	Max WHEEL RPM CLASS II	Max WHEEL RPM CLASS III	Max MOTOR FRAME CLASS I	Max MOTOR FRAME CLASS II	SHAFT DIAMETER (IN) CLASS I	SHAFT DIAMETER (IN) CLASS II	ESTIMATED FAN WEIGHT *(LBS)	
											CLASS I	CLASS II
KC-10	10 1/4	8	12	4134	4678	--	145 T	145 T	1	1 1/8	64	69
KC-12	12 1/2	11	16	3241	4051	--	182 T	184 T	1	1 1/8	86	93
KC-13	14	12	18	2844	3604	--	182 T	184 T	1	1 1/8	108	115
KC-15	15 1/8	14	21	2391	3165	3616	184 T	184 T	1 1/8	1 3/8	115	125
KC-16	16 11/16	17	26	2360	3106	3413	184 T	184 T	1 1/8	1 3/8	176	192
KC-18	18 9/16	25	40	2058	2717	3204	184 T	215 T	1 3/8	1 5/8	180	195
KC-20	20 7/16	32	52	2007	2448	2709	213 T	215 T	1 3/8	1 5/8	225	245
KC-22	22 9/16	39	60	1682	2298	2444	213 T	254 T	1 5/8	1 5/8	337	356
KC-24	24 5/8	73	79	1540	2053	2240	215 T	256 T	1 5/8	1 5/8	403	467

* Peso ventilador sin motor y transmisión

* Fan weight without motor and drive

KCB-10



Especificaciones técnicas / Performance data

Diametro de Turbina = 10 1/4" Diametro de Descarga= 16" Area de Descarga = 1.396 Ft ² RPM Max=Clase I 4134 Clase II 4678 Velocidad Tangencial (PPM)= 2.683 X RPM BHP Max =0.0356 (RPM/1000) ³	Wheel Diameter = 10 1/4" Outlet Diameter= 16" Outlet Area= 1.396 Ft ² RPM Max=Clase I 4134 Clase II 4678 Tip speed (FPM)= 2.683 X RPM Max. BHP = 0.0356 (RPM/1000) ³
--	---

Caudal (Air Flow)		Velocidad Descarga (Outlet Velocity)	Presión Estática en Pulgadas C.A. (Static Pressure in Inches W. G.)																			
			0.25"		0.5"		0.75"		1"		1.25"		1.5"		2"		2.5"		3"		3.5"	
CFM	M ³ /HR	FPM	RPM	BHP	RPM	BHP	RPM	BHP	RPM	BHP	RPM	BHP	RPM	BHP	RPM	BHP	RPM	BHP	RPM	BHP	RPM	BHP
558	949	400	1131	0.05	1394	0.10	1626	0.15	1839	0.22	--	--	--	--	--	--	--	--	--	--	--	--
698	1186	500	1279	0.07	1512	0.12	1718	0.18	1909	0.25	2088	0.32	2258	0.41	--	--	--	--	--	--	--	--
838	1423	600	1436	0.11	1650	0.16	1836	0.22	2009	0.29	2172	0.36	2328	0.45	2621	0.64	2893	0.86	--	--	--	--
977	1660	700	1602	0.15	1799	0.21	1971	0.27	2129	0.34	2279	0.42	2422	0.51	2693	0.70	2948	0.91	3190	1.16	3419	1.42
1117	1897	800	1776	0.20	1955	0.27	2116	0.34	2264	0.41	2403	0.49	2536	0.58	2788	0.77	3026	0.99	3253	1.23	3470	1.49
1256	2135	900	1958	0.27	2116	0.34	2269	0.42	2408	0.50	2539	0.58	2663	0.67	2900	0.87	3123	1.08	3337	1.32	3541	1.58
1396	2372	1000	2143	0.35	2273	0.42	2426	0.51	2559	0.60	2683	0.69	2801	0.78	3024	0.98	3235	1.20	3436	1.44	3630	1.70
1536	2609	1100	2327	0.45	2457	0.53	2588	0.62	2715	0.71	2833	0.81	2946	0.91	3158	1.12	3358	1.35	3548	1.59	3732	1.85
1675	2846	1200	2510	0.56	2635	0.65	2755	0.74	2874	0.85	2988	0.95	3096	1.06	3299	1.28	3490	1.51	3672	1.76	3847	2.03
1815	3083	1300	2697	0.70	2819	0.80	2926	0.89	3037	1.00	3146	1.11	3250	1.22	3446	1.46	3629	1.70	3803	1.96	3971	2.23
1954	3321	1400	2892	0.86	3004	0.97	3102	1.06	3205	1.17	3308	1.29	3408	1.41	3597	1.66	3774	1.91	3942	2.18	4102	2.46
2094	3558	1500	3088	1.05	3188	1.15	3283	1.26	3377	1.37	3473	1.49	3569	1.62	3752	1.88	3923	2.15	4085	2.43	4240	2.71
2234	3795	1600	3266	1.24	3372	1.36	3467	1.48	3552	1.60	3642	1.72	3733	1.85	3909	2.13	4075	2.41	4233	2.70	4383	3.00
2373	4032	1700	3450	1.46	3555	1.60	3652	1.73	3733	1.85	3816	1.98	3900	2.11	4069	2.40	4231	2.70	4384	3.00	4530	3.31

Los números en negra representan la eficiencia Máxima

Bold figures Indicate maximum efficiency

Caudal (Air Flow)		Velocidad Descarga (Outlet Velocity)	Presión Estática en Pulgadas C.A. (Static Pressure in Inches W. G.)																			
			4"		4.5"		5"		5.5"		6"		6.5"		7"		7.5"		8"		8.5"	
CFM	M ³ /HR	FPM	RPM	BHP	RPM	BHP	RPM	BHP	RPM	BHP	RPM	BHP	RPM	BHP	RPM	BHP	RPM	BHP	RPM	BHP	RPM	BHP
1117	1897	800	3679	1.77	3879	2.08	--	--	--	--	--	--	--	--	--	--	--	--	--	--	--	--
1256	2135	900	3739	1.86	3930	2.16	4116	2.48	4295	2.82	4470	3.18	--	--	--	--	--	--	--	--	--	--
1396	2372	1000	3818	1.98	3999	2.28	4176	2.59	4348	2.93	4516	3.28	--	--	--	--	--	--	--	--	--	--
1536	2609	1100	3911	2.13	4084	2.42	4253	2.74	4418	3.07	4578	3.41	--	--	--	--	--	--	--	--	--	--
1675	2846	1200	4017	2.31	4182	2.60	4343	2.92	4501	3.25	4655	3.59	--	--	--	--	--	--	--	--	--	--
1815	3083	1300	4134	2.51	4291	2.81	4445	3.13	4596	3.46	--	--	--	--	--	--	--	--	--	--	--	--
1954	3321	1400	4258	2.75	4410	3.05	4558	3.37	--	--	--	--	--	--	--	--	--	--	--	--	--	--
2094	3558	1500	4390	3.01	4536	3.32	4678	3.64	--	--	--	--	--	--	--	--	--	--	--	--	--	--
2234	3795	1600	4528	3.30	4668	3.62	--	--	--	--	--	--	--	--	--	--	--	--	--	--	--	--
2373	4032	1700	4670	3.63	--	--	--	--	--	--	--	--	--	--	--	--	--	--	--	--	--	--

Los números en negra representan la eficiencia Máxima

Bold figures Indicate maximum efficiency

 Ventiladores Clase I Ventiladores Clase II

 Class I Fans Class II Fans

Curvas de operación Operation curves

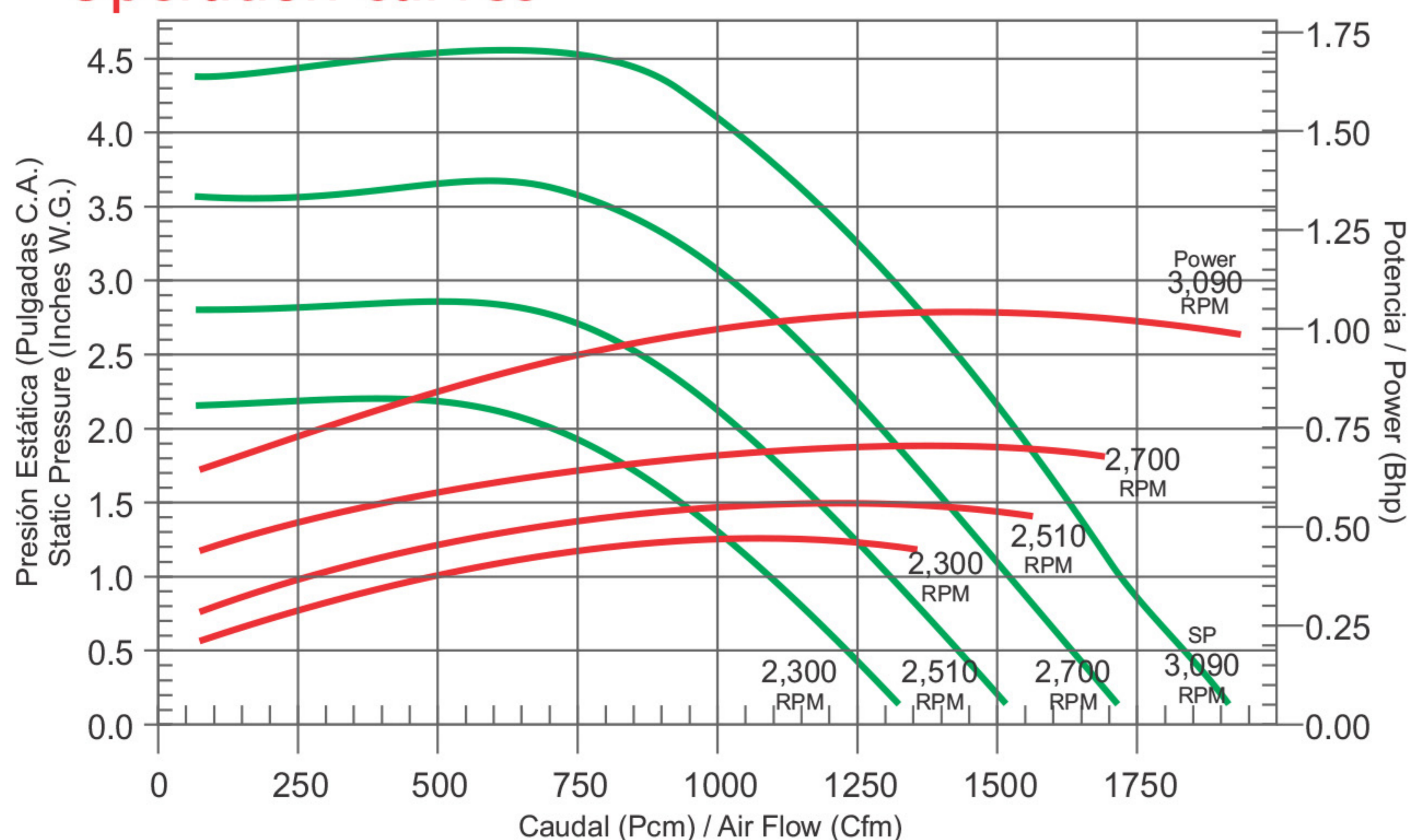

Espectros de potencia sonora Sound Power level ratings

	Freq.	63	125	250	500	1000	2000	4000	8000	Total	Hz
2300	LwA	90	79	78	80	77	77	76	69	91	dB(A)
2510	LwA	93	81	79	81	78	78	77	71	94	dB(A)
2700	LwA	97	83	79	82	80	78	78	72	98	dB(A)
3090	LwA	107	86	81	83	83	80	80	74	107	dB(A)

Datos obtenidos de acuerdo a la norma AMCA estándar 301 (Information obtained according to the AMCA Standard 301)

Todas las capacidades están basadas en la Densidad Estándar de Aire de 0.075 Lb/ft³ @ 70°F y 0 pies de Elevación: 1.2 kg/m³ @ 21°C y 0 mt
 (All Capacities are based on Standard Air Density of 0.075 Lb/ft³ @ 70°F and 0 Ft elevation: 1.2 kg/m³ @ 21°C and 0 mt)

KCB-12

Especificaciones técnicas / Performance data



Diametro de Turbina = 12 1/2" Diametro de Descarga= 18" Area de Descarga = 1.767 Ft ² RPM Max=Clase I 3241 Clase II 4051 Velocidad Tangencial (PPM)= 3.2738 X RPM BHP Max =0.0638 (RPM/1000) ³												Wheel Diameter = 12 1/2" Outlet Diameter= 18" Outlet Area= 1.767 Ft ² RPM Max=Clase I 3241 Clase II 4051 Tip speed (FPM)= 3.2738 X RPM Max. BHP = 0.0638 (RPM/1000) ³											
Presión Estática en Pulgadas C.A. (Static Pressure in Inches W. G.)																							
Caudal (Air Flow)		Velocidad Descarga (Outlet Velocity)		0.25"		0.5"		0.75"		1"		1.25"		1.5"		2"		2.5"		3"		3.5"	
CFM	M ³ /HR	FPM	RPM	BHP	RPM	BHP	RPM	BHP	RPM	BHP	RPM	BHP	RPM	BHP	RPM	BHP	RPM	BHP	RPM	BHP	RPM	BHP	
707	1201	400	789	0.03	1031	0.07	1242	0.12	--	--	--	--	--	--	--	--	--	--	--	--	--	--	
884	1501	500	871	0.04	1075	0.08	1266	0.13	1441	0.19	1601	0.26	--	--	--	--	--	--	--	--	--	--	
1060	1801	600	970	0.06	1141	0.09	1309	0.14	1470	0.20	1621	0.27	1762	0.35	--	--	--	--	--	--	--	--	
1237	2101	700	1081	0.08	1225	0.12	1372	0.16	1516	0.22	1655	0.29	1788	0.36	2036	0.54	2263	0.74	--	--	--	--	
1414	2402	800	1195	0.11	1322	0.15	1450	0.19	1579	0.25	1705	0.32	1828	0.39	2062	0.56	2281	0.76	2484	0.98	--	--	
1590	2702	900	1311	0.14	1428	0.19	1540	0.23	1655	0.29	1769	0.35	1882	0.42	2099	0.59	2307	0.78	2503	1.00	2688	1.24	
1767	3002	1000	1432	0.19	1539	0.23	1640	0.28	1742	0.34	1845	0.40	1948	0.47	2150	0.63	2345	0.82	2532	1.04	2710	1.27	
1944	3302	1100	1555	0.24	1614	0.27	1746	0.34	1838	0.40	1931	0.46	2025	0.53	2211	0.69	2394	0.88	2571	1.08	2741	1.31	
2120	3603	1200	1684	0.30	1769	0.35	1857	0.41	1941	0.47	2026	0.53	2110	0.60	2283	0.76	2453	0.94	2620	1.15	2782	1.37	
2297	3903	1300	1815	0.38	1888	0.43	1970	0.49	2049	0.55	2126	0.61	2205	0.68	2363	0.84	2521	1.02	2678	1.22	2832	1.45	
2474	4203	1400	1944	0.47	2007	0.52	2086	0.58	2160	0.64	2233	0.71	2304	0.78	2451	0.94	2598	1.12	2744	1.32	2889	1.54	
2651	4503	1500	2072	0.57	2130	0.62	2203	0.68	2274	0.75	2342	0.82	2409	0.89	2544	1.05	2682	1.23	2819	1.43	2956	1.65	
2827	4803	1600	2200	0.68	2256	0.73	2321	0.80	2389	0.87	2455	0.94	2517	1.02	2644	1.18	2772	1.36	2900	1.56	3029	1.77	
3004	5104	1700	2337	0.81	2385	0.87	2441	0.93	2505	1.00	2569	1.08	2629	1.16	2748	1.32	2868	1.50	2988	1.70	3109	1.92	
3181	5404	1800	2461	0.95	2515	1.02	2563	1.07	2624	1.15	2685	1.23	2742	1.32	2856	1.49	2967	1.67	3081	1.87	3195	2.08	

Los números en negro representan la eficiencia Máxima

Bold figures Indicate maximun efficiency

Presión Estática en Pulgadas C.A. (Static Pressure in Inches W. G.)																							
Caudal (Air Flow)		Velocidad Descarga (Outlet Velocity)		4"		4.5"		5"		5.5"		6"		6.5"		7"		7.5"		8"		8.5"	
CFM	M ³ /HR	FPM	RPM	BHP	RPM	BHP	RPM	BHP	RPM	BHP	RPM	BHP	RPM	BHP	RPM	BHP	RPM	BHP	RPM	BHP	RPM	BHP	
1767	3002	1000	2882	1.53	3045	1.80	3202	2.09	--	--	--	--	--	--	--	--	--	--	--	--	--	--	
1944	3302	1100	2906	1.57	3066	1.84	3218	2.13	3365	2.43	3507	2.75	--	--	--	--	--	--	--	--	--	--	
2120	3603	1200	2940	1.62	3092	1.89	3241	2.17	3385	2.47	3524	2.79	3660	3.13	3790	3.47	3917	3.84	--	--	--	--	
2297	3903	1300	2982	1.69	3128	1.95	3272	2.23	3411	2.53	3546	2.85	3679	3.18	3807	3.52	3932	3.88	--	--	--	--	
2474	4203	1400	3033	1.78	3173	2.04	3310	2.31	3445	2.61	3576	2.92	3704	3.24	3830	3.58	3952	3.94	--	--	--	--	
2651	4503	1500	3091	1.89	3225	2.14	3356	2.41	3485	2.70	3612	3.01	3736	3.33	3859	3.67	3978	4.02	--	--	--	--	
2827	4803	1600	3157	2.01	3284	2.26	3410	2.53	3534	2.82	3656	3.12	3776	3.43	3893	3.77	4010	4.11	--	--	--	--	
3004	5104	1700	3231	2.15	3351	2.40	3471	2.67	3589	2.95	3706	3.25	3822	3.56	3935	3.89	4048	4.23	--	--	--	--	
3181	5404	1800	3309	2.31	3424	2.56	3538	2.83	3651	3.10	3763	3.40	3875	3.71	3984	4.03	--	--	--	--	--	--	
3357	5704	1900	3394	2.49	3502	2.74	3611	3.00	3719	3.28	3827	3.58	3933	3.88	4039	4.20	--	--	--	--	--	--	
3534	6004	2000	3483	2.70	3587	2.94	3689	3.20	3793	3.48	3895	3.77	3998	4.08	--	--	--	--	--	--	--	--	
3887	6605	2200	3676	3.17	3769	3.42	3862	3.67	3956	3.95	4050	4.24	--	--	--	--	--	--	--	--	--	--	
4241	7205	2400	3881	3.73	3966	3.98	4051	4.24	--	--	--	--	--	--	--	--	--	--	--	--	--	--	

Los números en negro representan la eficiencia Máxima

Bold figures Indicate maximun efficiency

Ventiladores Clase I Ventiladores Clase II

Class I Fans Class II Fans

Curvas de operación Operation curves

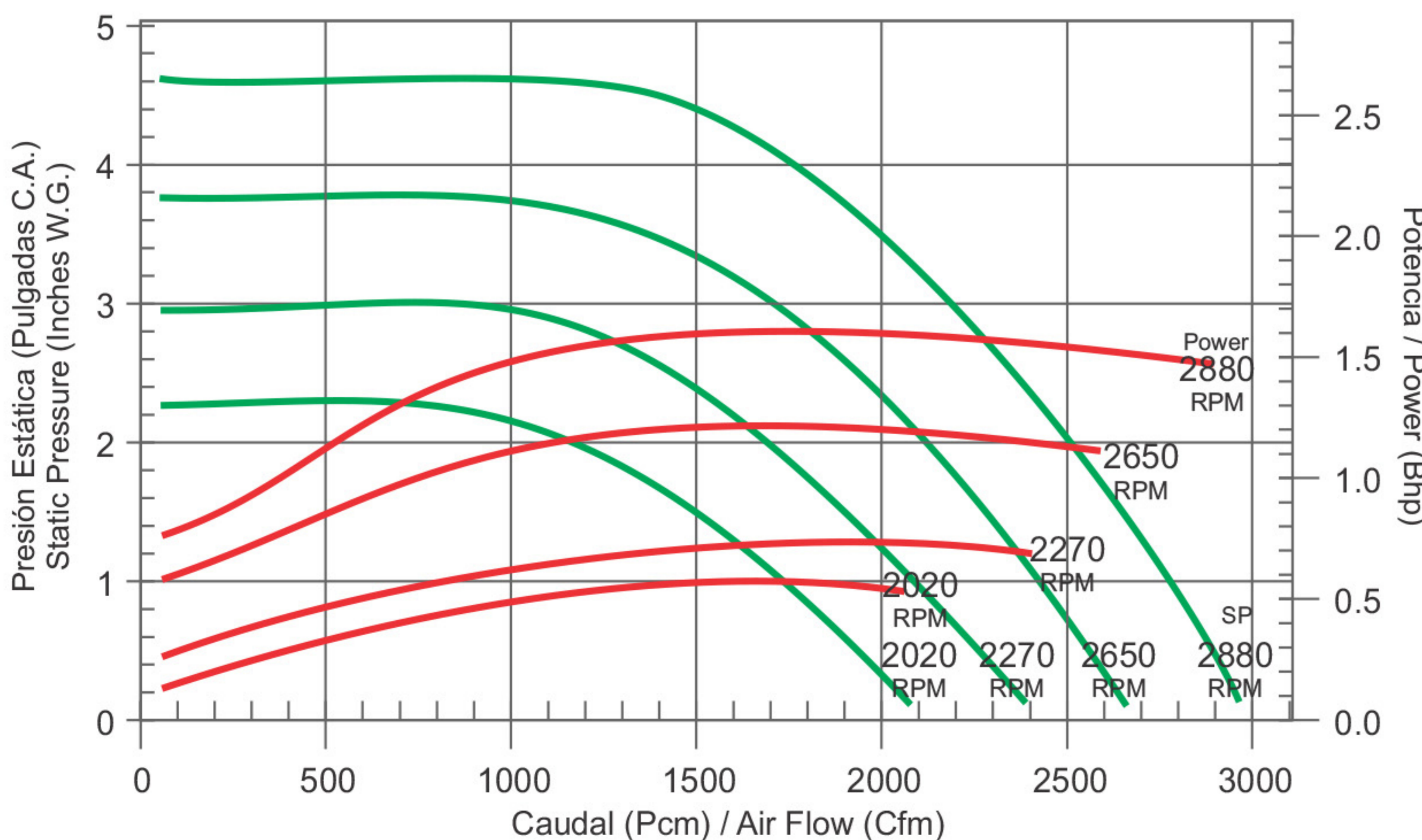

Espectros de potencia sonora Sound Power level ratings

	Freq.	63	125	250	500	1000	2000	4000	8000	Total	Hz
2020	LwA	86	76	77	78	74	76	74	66	88	dB(A)
2270	LwA	89	79	78	80	77	77	75	69	91	dB(A)
2650	LwA	96	82	79	82	79	78	77	72	96	dB(A)
2880	LwA	103	84	80	83	81	79	78	73	103	dB(A)

Datos obtenidos de acuerdo a la norma AMCA estándar 301 (Information obtained according to the AMCA Standard 301)

Todas las capacidades están basadas en la Densidad Estándar de Aire de 0.075 Lb/ft³ @ 70°F y 0 pies de Elevación: 1.2 kg/m³ @ 21°C y 0 mt
 (All Capacities are based on Standard Air Density of 0.075 Lb/ft³ @ 70°F and 0 Ft elevation: 1.2 kg/m³ @ 21°C and 0 mt)

KCB-13

Especificaciones técnicas / Performance data



Diametro de Turbina = 14" Diametro de Descarga= 21" Area de Descarga = 2.405 Ft ² RPM Max=Clase I 2844 Clase II 3604 Velocidad Tangencial (PPM)=3.665 X RPM BHP Max =0.1209 (RPM/1000) ³	Wheel Diameter = 14" Outlet Diameter= 21" Outlet Area= 2.405 Ft ² RPM Max=Clase I 2844 Clase II 3604 Tip speed (FPM)= 3.665 X RPM Max. BHP = 0.1209 (RPM/1000) ³
---	---

Caudal (Air Flow)		Velocidad Descarga (Outlet Velocity)	Presión Estática en Pulgadas C.A. (Static Pressure in Inches W. G.)																			
			0.25"		0.5"		0.75"		1"		1.25"		1.5"		2"		2.5"		3"		3.5"	
CFM	M ³ /HR	FPM	RPM	BHP	RPM	BHP	RPM	BHP	RPM	BHP	RPM	BHP	RPM	BHP	RPM	BHP	RPM	BHP	RPM	BHP	RPM	BHP
962	1634	400	703	0.04	917	0.09	1105	0.16	--	--	--	--	--	--	--	--	--	--	--	--	--	--
1203	2043	500	775	0.06	956	0.11	1126	0.17	1282	0.26	1425	0.35	--	--	--	--	--	--	--	--	--	--
1443	2452	600	864	0.08	1016	0.13	1166	0.19	1308	0.27	1443	0.36	1568	0.47	--	--	--	--	--	--	--	--
1684	2860	700	961	0.11	1090	0.16	1221	0.22	1350	0.30	1473	0.39	1592	0.49	1812	0.72	2014	0.99	--	--	--	--
1924	3269	800	1064	0.15	1177	0.20	1291	0.26	1405	0.34	1518	0.42	1627	0.52	1835	0.75	2029	1.01	2211	1.31	--	--
2165	3677	900	1167	0.19	1271	0.25	1371	0.31	1473	0.39	1574	0.47	1675	0.57	1869	0.79	2054	1.05	2228	1.34	2393	1.66
2405	4086	1000	1275	0.25	1369	0.31	1459	0.38	1551	0.45	1643	0.54	1733	0.63	1914	0.85	2088	1.10	2254	1.38	2413	1.70
2646	4495	1100	1384	0.32	1472	0.39	1554	0.45	1636	0.53	1719	0.61	1803	0.71	1969	0.92	2131	1.17	2288	1.45	2440	1.76
2886	4903	1200	1498	0.41	1575	0.47	1652	0.55	1728	0.62	1803	0.71	1879	0.80	2032	1.01	2183	1.26	2332	1.53	2476	1.84
3127	5312	1300	1615	0.51	1680	0.57	1754	0.65	1823	0.73	1892	0.82	1962	0.91	2103	1.12	2244	1.37	2383	1.64	2520	1.93
3367	5721	1400	1730	0.63	1787	0.69	1856	0.77	1923	0.86	1987	0.95	2052	1.04	2181	1.25	2312	1.49	2443	1.76	2572	2.06
3608	6129	1500	1844	0.76	1895	0.82	1961	0.91	2024	1.00	2085	1.10	2144	1.19	2264	1.40	2386	1.64	2509	1.91	2631	2.20
3848	6538	1600	1958	0.91	2008	0.98	2066	1.07	2127	1.16	2184	1.26	2241	1.36	2353	1.58	2467	1.82	2582	2.08	2697	2.37
4089	6946	1700	2080	1.09	2123	1.16	2173	1.24	2230	1.34	2287	1.45	2340	1.55	2446	1.77	2552	2.01	2660	2.27	2767	2.56
4329	7355	1800	2199	1.27	2239	1.36	2281	1.43	2336	1.54	2389	1.65	2441	1.76	2542	1.98	2641	2.23	2742	2.49	2844	2.78

Los números en negro representan la eficiencia Máxima

Bold figures Indicate maximum efficiency

Caudal (Air Flow)		Velocidad Descarga (Outlet Velocity)	Presión Estática en Pulgadas C.A. (Static Pressure in Inches W. G.)																			
			4"		4.5"		5"		5.5"		6"		6.5"		7"		7.5"		8"		8.5"	
CFM	M ³ /HR	FPM	RPM	BHP	RPM	BHP	RPM	BHP	RPM	BHP	RPM	BHP	RPM	BHP	RPM	BHP	RPM	BHP	RPM	BHP	RPM	BHP
2405	4086	1000	2565	2.04	2710	2.41	2850	2.80	--	--	--	--	--	--	--	--	--	--	--	--	--	--
2646	4495	1100	2587	2.09	2728	2.45	2865	2.84	2995	3.25	3122	3.68	3244	4.13	--	--	--	--	--	--	--	--
2886	4903	1200	2617	2.17	2753	2.52	2885	2.90	3013	3.31	3137	3.73	3257	4.18	3374	4.64	3487	5.13	--	--	--	--
3127	5312	1300	2654	2.26	2785	2.61	2912	2.99	3036	3.38	3156	3.80	3274	4.24	3389	4.70	3500	5.18	--	--	--	--
3367	5721	1400	2700	2.38	2825	2.72	2947	3.09	3066	3.48	3183	3.90	3297	4.33	3409	4.79	3518	5.26	--	--	--	--
3608	6129	1500	2751	2.52	2870	2.86	2988	3.22	3103	3.61	3215	4.02	3326	4.45	3435	4.90	3541	5.37	--	--	--	--
3848	6538	1600	2811	2.69	2923	3.02	3035	3.38	3146	3.76	3254	4.17	3360	4.59	3466	5.03	3569	5.50	--	--	--	--
4089	6946	1700	2875	2.87	2983	3.21	3089	3.56	3194	3.94	3299	4.34	3401	4.76	3503	5.20	3603	5.66	--	--	--	--
4329	7355	1800	2946	3.09	3048	3.42	3149	3.77	3250	4.15	3350	4.54	3448	4.96	3546	5.39	--	--	--	--	--	--
4570	7764	1900	3021	3.33	3117	3.66	3214	4.01	3311	4.39	3406	4.78	3501	5.19	3595	5.62	--	--	--	--	--	--
4810	8172	2000	3101	3.60	3192	3.93	3284	4.28	3376	4.65	3468	5.04	3558	5.45	--	--	--	--	--	--	--	--
5291	8989	2200	3272	4.23	3355	4.56	3437	4.91	3520	5.27	3604	5.66	--	--	--	--	--	--	--	--	--	--
5772	9807	2400	3455	4.99	3530	5.32	--	--	--	--	--	--	--	--	--	--	--	--	--	--	--	--

Los números en negro representan la eficiencia Máxima

Bold figures Indicate maximum efficiency

Ventiladores Clase I
 Ventiladores Clase II

Class I Fans
 Class II Fans

Curvas de operación Operation curves

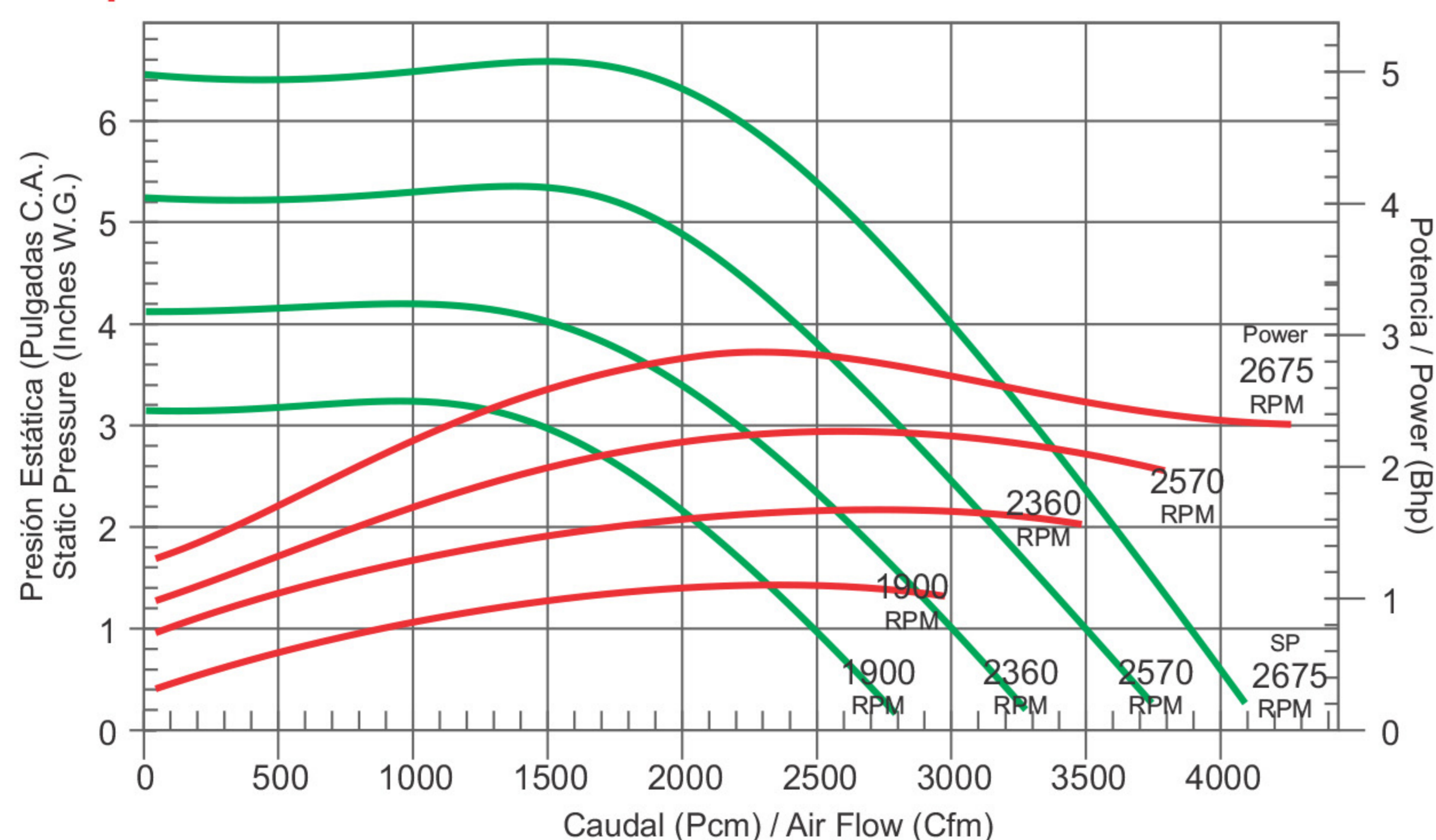

Espectros de potencia sonora Sound Power level ratings

	Freq.	63	125	250	500	1000	2000	4000	8000	Total	Hz
1900	LwA	91	81	83	83	79	82	79	71	93	dB(A)
2360	LwA	97	86	85	87	83	84	82	76	98	dB(A)
2570	LwA	100	88	86	88	85	85	83	78	101	dB(A)
2675	LwA	102	89	86	88	86	85	83	78	103	dB(A)

Datos obtenidos de acuerdo a la norma AMCA estándar 301
(Information obtained according to the AMCA Standard 301)

Todas las capacidades están basadas en la Densidad Estándar de Aire de 0.075 Lb/ft³ @ 70°F y 0 pies de Elevación: 1.2 kg/m³ @ 21°C y 0 mt
(All Capacities are based on Standard Air Density of 0.075 Lb/ft³ @ 70°F and 0 Ft elevation: 1.2 kg/m³ @ 21°C and 0 mt)

KCB-15



Especificaciones técnicas / Performance data

Diametro de Turbina = 15 1/8" Diametro de Descarga= 24" Area de Descarga = 3.142 Ft² RPM Max=Clase I [2391] Clase II [3165] Clase III [3616] Velocidad Tangencial (PPM)=3.96 X RPM BHP Max =0.174 (RPM/1000)³	Wheel Diameter = 15 1/8" Outlet Diameter= 24" Outlet Area= 3.142 Ft² RPM Max=Clase I [2391] Clase II [3165] Clase III [3616] Tip speed (FPM)= 3.96 X RPM Max. BHP = 0.174 (RPM/1000)³
--	--

Caudal (Air Flow)		Velocidad Descarga (Outlet Velocity)	Presión Estática en Pulgadas C.A. (Static Pressure in Inches W. G.)																			
			0.25"		0.5"		0.75"		1"		1.25"		1.5"		2"		2.5"		3"		3.5"	
CFM	M ³ /HR	FPM	RPM	BHP	RPM	BHP	RPM	BHP	RPM	BHP	RPM	BHP	RPM	BHP	RPM	BHP	RPM	BHP	RPM	BHP	RPM	BHP
1885	3203	600	761	0.08	901	0.13	1043	0.20	1180	0.29	1309	0.39	--	--	--	--	--	--	--	--	--	--
2199	3737	700	846	0.11	963	0.16	1085	0.22	1207	0.31	1325	0.40	1439	0.52	--	--	--	--	--	--	--	--
2514	4271	800	937	0.14	1038	0.19	1142	0.26	1249	0.34	1355	0.43	1460	0.54	1660	0.80	--	--	--	--	--	--
2828	4804	900	1031	0.19	1119	0.24	1211	0.31	1304	0.39	1399	0.48	1494	0.58	1680	0.83	1858	1.12	--	--	--	--
3142	5338	1000	1128	0.25	1206	0.31	1287	0.37	1369	0.45	1454	0.54	1540	0.64	1710	0.87	1877	1.15	2037	1.47	2190	1.83
3456	5872	1100	1227	0.32	1296	0.38	1369	0.45	1443	0.52	1519	0.61	1596	0.71	1751	0.93	1906	1.20	2057	1.51	2203	1.86
3770	6406	1200	1328	0.41	1389	0.47	1455	0.54	1523	0.61	1591	0.70	1660	0.80	1802	1.02	1945	1.28	2086	1.58	2225	1.92
4085	6940	1300	1427	0.51	1483	0.57	1544	0.64	1606	0.72	1668	0.81	1732	0.90	1861	1.12	1992	1.38	2124	1.67	2254	1.99
4399	7474	1400	1526	0.62	1581	0.69	1635	0.76	1693	0.84	1750	0.93	1808	1.03	1926	1.24	2048	1.49	2170	1.78	2292	2.10
4713	8007	1500	1623	0.74	1680	0.83	1729	0.90	1782	0.98	1836	1.08	1889	1.17	1999	1.39	2110	1.64	2224	1.91	2338	2.22
5027	8541	1600	1724	0.89	1781	0.98	1825	1.06	1873	1.14	1923	1.24	1973	1.34	2075	1.55	2179	1.80	2284	2.07	2391	2.38
5341	9075	1700	1828	1.06	1881	1.16	1922	1.23	1967	1.32	2013	1.42	2060	1.52	2155	1.74	2252	1.99	2350	2.26	2450	2.56
5656	9609	1800	1932	1.26	1980	1.35	2021	1.44	2061	1.52	2104	1.62	2148	1.73	2238	1.95	2328	2.20	2420	2.47	2514	2.77
5970	10143	1900	2035	1.47	2079	1.56	2121	1.66	2158	1.75	2197	1.85	2239	1.95	2323	2.18	2409	2.43	2496	2.70	2583	3.00
6284	10677	2000	2136	1.70	2177	1.79	2221	1.91	2256	2.00	2292	2.10	2331	2.20	2412	2.44	2492	2.69	2573	2.96	2656	3.26
6912	11744	2200	2355	2.27	2375	2.33	2420	2.47	2455	2.57	2487	2.68	2520	2.78	2591	3.03	2664	3.29	2737	3.57	2811	3.87

Los números en negro representan la eficiencia Máxima

Bold figures Indicate maximun efficiency

Caudal (Air Flow)		Velocidad Descarga (Outlet Velocity)	Presión Estática en Pulgadas C.A. (Static Pressure in Inches W. G.)																			
			4"		4.5"		5"		5.5"		6"		6.5"		7"		7.5"		8"		8.5"	
CFM	M ³ /HR	FPM	RPM	BHP	RPM	BHP	RPM	BHP	RPM	BHP	RPM	BHP	RPM	BHP	RPM	BHP	RPM	BHP	RPM	BHP	RPM	BHP
3770	6406	1200	2360	2.29	2484	2.67	2618	3.12	--	--	--	--	--	--	--	--	--	--	--	--	--	--
4085	6940	1300	2383	2.36	2508	2.75	2632	3.17	2751	3.62	2866	4.10	--	--	--	--	--	--	--	--	--	--
4399	7474	1400	2413	2.45	2534	2.83	2651	3.24	2766	3.68	2879	4.15	2988	4.64	3096	5.16	--	--	--	--	--	--
4713	8007	1500	2453	2.57	2565	2.94	2677	3.34	2788	3.77	2897	4.23	3003	4.71	3108	5.22	3209	5.75	3310	6.31	--	--
5027	8541	1600	2498	2.71	2605	3.08	2711	3.47	2816	3.89	2921	4.34	3024	4.81	3124	5.31	3224	5.83	3322	6.38	3418	6.95
5341	9075	1700	2550	2.89	2651	3.24	2752	3.63	2852	4.03	2951	4.47	3050	4.94	3147	5.42	3244	5.94	3339	6.47	3431	7.03
5656	9609	1800	2608	3.09	2703	3.44	2798	3.81	2894	4.22	2988	4.64	3082	5.10	3175	5.57	3268	6.07	3360	6.60	3451	7.15
5970	10143	1900	2672	3.32	2761	3.66	2851	4.03	2941	4.42	3031	4.84	3120	5.29	3210	5.76	3299	6.25	3387	6.76	3474	7.30
6284	10677	2000	2739	3.58	2823	3.92	2908	4.28	2993	4.67	3079	5.08	3165	5.52	3251	5.98	3336	6.46	3421	6.96	3505	7.49
6912	11744	2200	2886	4.18	2961	4.52	3037	4.88	3115	5.26	3192	5.66	3269	6.08	3347	6.53	3425	6.99	3503	7.48	3580	7.98
7541	12812	2400	3044	4.91	3113	5.25	3181	5.60	3251	5.98	3320	6.37	3390	6.78	3462	7.22	3533	7.67	3604	8.14	--	--
8169	13879	2600	3211	5.76	3274	6.11	3337	6.46	3399	6.83	3463	7.22	3527	7.64	3592	8.06	--	--	--	--	--	--
8798	14947	2800	3385	6.75	3442	7.10	3500	7.46	3588	8.04	3616	8.23	--	--	--	--	--	--	--	--	--	--

Los números en negro representan la eficiencia Máxima

Bold figures Indicate maximun efficiency

Ventiladores Clase I
 Ventiladores Clase II
 Ventiladores Clase III

Class I Fans
 Class II Fans
 Class III Fans

Curvas de operación Operation curves

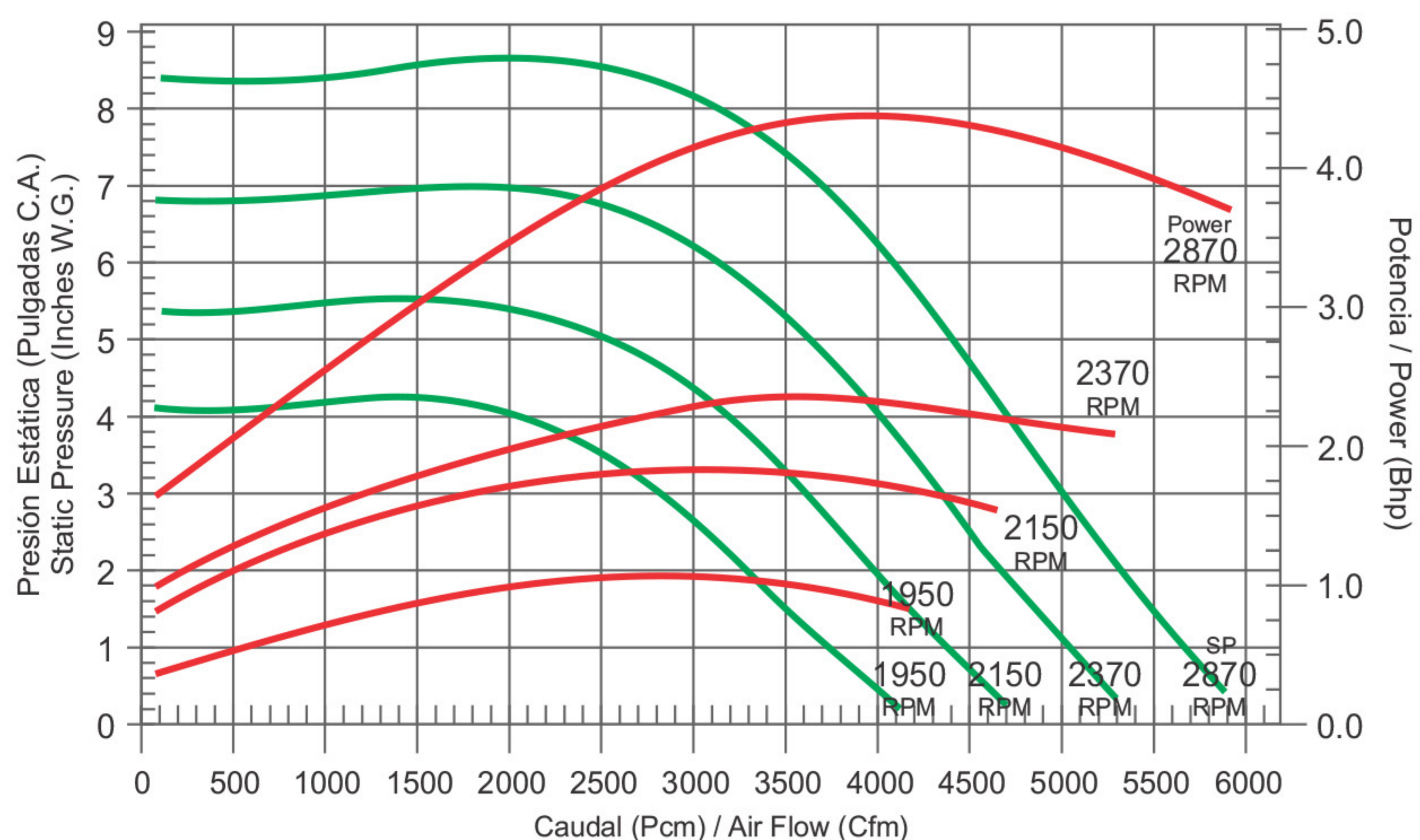

Espectros de potencia sonora Sound Power level ratings

	Freq.	63	125	250	500	1000	2000	4000	8000	Total	Hz
1950	LwA	92	82	83	84	80	82	79	72	94	dB(A)
2150	LwA	94	84	84	86	82	83	81	75	96	dB(A)
2370	LwA	97	86	85	87	83	84	82	76	98	dB(A)
2870	LwA	109	90	86	89	87	86	85	79	109	dB(A)

Datos obtenidos de acuerdo a la norma AMCA estándar 301
(Information obtained according to the AMCA Standard 301)

Todas las capacidades están basadas en la Densidad Estándar de Aire de 0.075 Lb/ft³ @ 70°F y 0 pies de Elevación: 1.2 kg/m³ @ 21°C y 0 mt
(All Capacities are based on Standard Air Density of 0.075 Lb/ft³ @ 70°F and 0 Ft elevation: 1.2 kg/m³ @ 21°C and 0 mt)

KCB-16



Especificaciones técnicas / Performance data

Diametro de Turbina = 16 11/16" Diametro de Descarga= 26" Area de Descarga = 3.687 Ft ² RPM Max=Clase I 2360 Clase II 3106 Clase III 3413 Velocidad Tangencial (PPM)=4.369 X RPM BHP Max =0.3371 (RPM/1000) ³	Wheel Diameter = 16 11/16" Outlet Diameter= 26" Outlet Area= 3.687 Ft ² RPM Max=Clase I 2360 Clase II 3106 Clase III 3413 Tip speed (FPM)= 4.369 X RPM Max. BHP = 0.3371 (RPM/1000) ³
---	---

Caudal (Air Flow)		Velocidad Descarga (Outlet Velocity)	Presión Estática en Pulgadas C.A. (Static Pressure in Inches W. G.)																			
			0.25"		0.5"		0.75"		1"		1.25"		1.5"		2"		2.5"		3"		3.5"	
CFM	M ³ /HR	FPM	RPM	BHP	RPM	BHP	RPM	BHP	RPM	BHP	RPM	BHP	RPM	BHP	RPM	BHP	RPM	BHP	RPM	BHP	RPM	BHP
2212	3759	600	696	0.11	824	0.19	954	0.29	1078	0.42	1196	0.58	--	--	--	--	--	--	--	--	--	--
2581	4385	700	774	0.16	881	0.23	992	0.33	1103	0.45	1211	0.60	1315	0.77	--	--	--	--	--	--	--	--
2950	5011	800	856	0.21	948	0.29	1044	0.38	1141	0.50	1239	0.64	1335	0.80	1518	1.18	--	--	--	--	--	--
3318	5638	900	942	0.28	1022	0.36	1106	0.46	1191	0.57	1279	0.71	1365	0.86	1535	1.22	1698	1.65	--	--	--	--
3687	6264	1000	1031	0.37	1102	0.45	1176	0.55	1251	0.66	1329	0.79	1407	0.94	1563	1.29	1715	1.70	1862	2.18	2001	2.70
4056	6891	1100	1122	0.48	1184	0.56	1250	0.66	1318	0.77	1388	0.90	1458	1.04	1600	1.38	1742	1.78	1879	2.24	2013	2.75
4424	7517	1200	1213	0.60	1269	0.69	1329	0.79	1391	0.91	1454	1.04	1517	1.18	1647	1.50	1777	1.89	1906	2.33	2033	2.83
4793	8143	1300	1304	0.75	1356	0.84	1411	0.95	1468	1.07	1525	1.19	1583	1.34	1701	1.66	1821	2.03	1941	2.47	2060	2.95
5162	8770	1400	1394	0.91	1445	1.02	1494	1.12	1546	1.25	1599	1.38	1652	1.52	1761	1.84	1872	2.21	1984	2.63	2095	3.10
5531	9396	1500	1483	1.10	1535	1.22	1580	1.33	1628	1.45	1677	1.59	1726	1.73	1826	2.05	1929	2.42	2032	2.83	2137	3.29
5899	10023	1600	1576	1.32	1627	1.45	1667	1.56	1711	1.69	1758	1.83	1803	1.98	1896	2.30	1991	2.66	2087	3.06	2185	3.52
6268	10649	1700	1670	1.57	1718	1.71	1757	1.83	1797	1.96	1839	2.10	1882	2.25	1969	2.57	2057	2.94	2148	3.34	2238	3.78
6637	11276	1800	1765	1.85	1810	2.00	1847	2.12	1883	2.25	1923	2.40	1964	2.55	2046	2.89	2128	3.25	2212	3.65	2297	4.09
7005	11902	1900	1860	2.17	1899	2.31	1938	2.46	1972	2.58	2008	2.73	2047	2.89	2123	3.23	2201	3.59	2281	4.00	2360	4.43
7374	12528	2000	1951	2.50	1989	2.65	2030	2.82	2061	2.95	2095	3.10	2130	3.26	2204	3.61	2278	3.98	2351	4.38	2427	4.82
8111	13781	2200	2152	3.36	2170	3.45	2212	3.65	2243	3.81	2273	3.96	2303	4.12	2368	4.48	2435	4.87	2502	5.28	2569	5.71

Los números en negro representan la eficiencia Máxima

Bold figures Indicate maximun efficiency

Caudal (Air Flow)		Velocidad Descarga (Outlet Velocity)	Presión Estática en Pulgadas C.A. (Static Pressure in Inches W. G.)																			
			4"		4.5"		5"		5.5"		6"		6.5"		7"		7.5"		8"		8.5"	
CFM	M ³ /HR	FPM	RPM	BHP	RPM	BHP	RPM	BHP	RPM	BHP	RPM	BHP	RPM	BHP	RPM	BHP	RPM	BHP	RPM	BHP	RPM	BHP
4424	7517	1200	2157	3.38	2277	3.98	2393	4.62	--	--	--	--	--	--	--	--	--	--	--	--	--	--
4793	8143	1300	2177	3.48	2292	4.06	2404	4.69	2514	5.35	2620	6.06	--	--	--	--	--	--	--	--	--	--
5162	8770	1400	2206	3.62	2315	4.18	2422	4.79	2527	5.44	2631	6.14	2731	6.86	2829	7.63	--	--	--	--	--	--
5531	9396	1500	2241	3.80	2344	4.34	2447	4.94	2548	5.58	2647	6.25	2745	6.97	2840	7.72	2933	8.51	3025	9.33	--	--
5899	10023	1600	2283	4.01	2380	4.54	2477	5.12	2573	5.75	2669	6.41	2763	7.11	2856	7.85	2946	8.62	3036	9.43	3123	10.27
6268	10649	1700	2331	4.27	2422	4.79	2515	5.36	2606	5.97	2696	6.61	2787	7.30	2876	8.02	2964	8.78	3050	9.57	3136	10.39
6637	11276	1800	2384	4.57	2470	5.08	2557	5.63	2644	6.23	2731	6.86	2816	7.53	2902	8.24	2986	8.98	3071	9.76	3153	10.57
7005	11902	1900	2441	4.90	2522	5.41	2605	5.96	2688	6.54	2770	7.17	2852	7.82	2933	8.51	3015	9.24	3095	10.00	3175	10.79
7374	12528	2000	2503	5.28	2580	5.79	2658	6.33	2736	6.90	2814	7.51	2892	8.15	2971	8.84	3048	9.55	3126	10.30	3203	11.07
8111	13781	2200	2637	6.18	2706	6.68	2776	7.21	2846	7.77	2917	8.36	2987	8.99	3058	9.64	3130	10.34	3201	11.05	3271	11.80
8849	15034	2400	2782	7.26	2844	7.75	2907	8.28	2971	8.84	3035	9.42	3098	10.03	3163	10.67	3228	11.34	3293	12.04	3359	12.77
9586	16287	2600	2935	8.52	2991	9.02	3049	9.56	3106	10.10	3164	10.68	3223	11.29	3282	11.92	3341	12.57	3401	13.26	--	--
10324	17540	2800	3094	9.98	3146	10.49	3199	11.03	3252	11.59	3305	12.17	3359	12.77	3413	13.40	--	--	--	--	--	--

Los números en negro representan la eficiencia Máxima

Bold figures Indicate maximun efficiency

Ventiladores Clase I
 Ventiladores Clase II
 Ventiladores Clase III

Class I Fans
 Class II Fans
 Class III Fans

Curvas de operación Operation curves

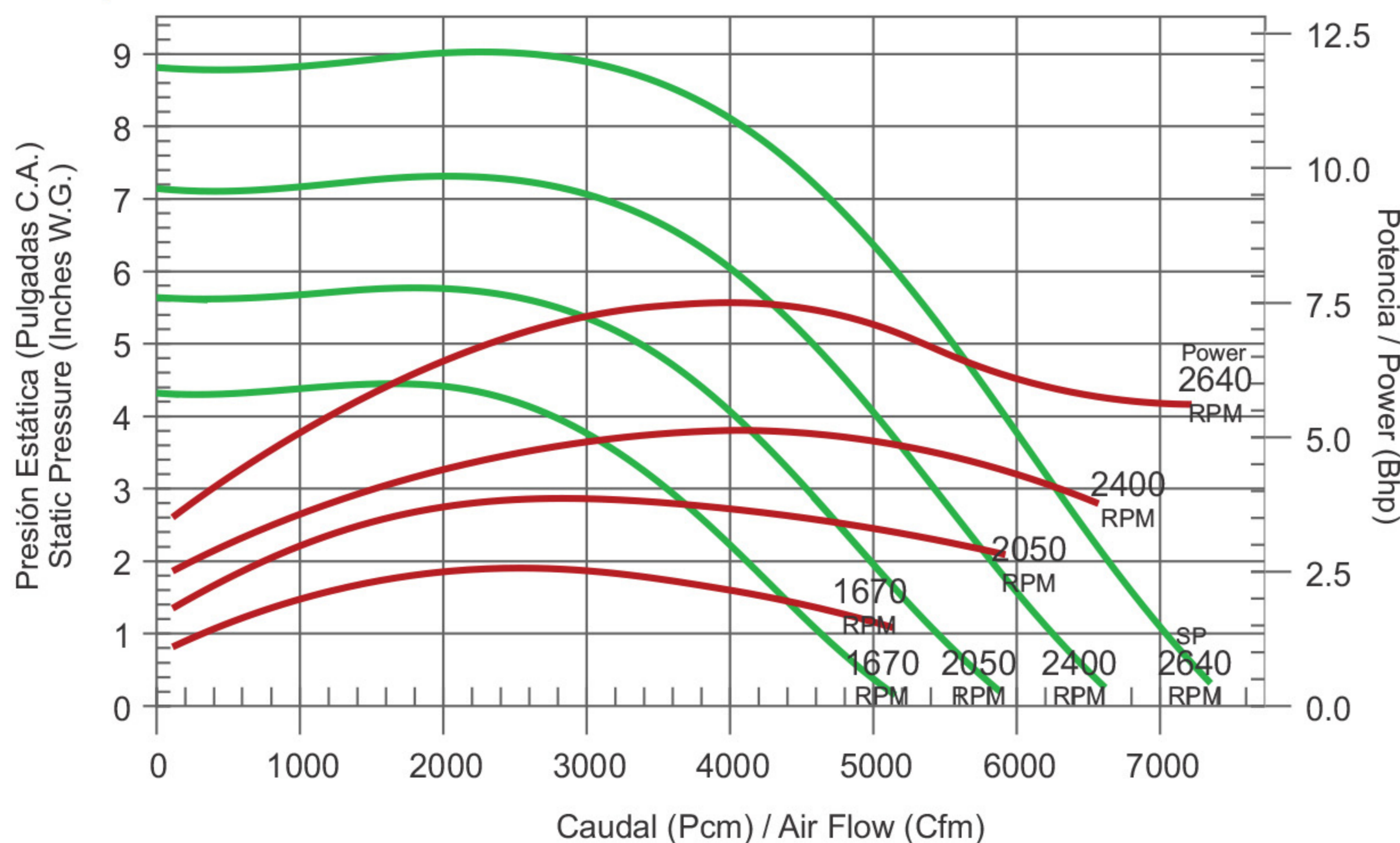

Espectros de potencia sonora Sound Power level ratings

	Freq.	63	125	250	500	1000	2000	4000	8000	Total	Hz
1670	LwA	85	86	85	80	77	76	71	63	91	dB(A)
2050	LwA	89	87	88	85	81	80	76	68	94	dB(A)
2400	LwA	91	88	89	89	83	83	79	72	96	dB(A)
2640	LwA	92	90	89	91	84	84	81	75	97	dB(A)

Datos obtenidos de acuerdo a la norma AMCA estándar 301
(Information obtained according to the AMCA Standard 301)

Todas las capacidades están basadas en la Densidad Estándar de Aire de 0.075 Lb/ft³ @ 70°F y 0 pies de Elevación: 1.2 kg/m³ @ 21°C y 0 mt
(All Capacities are based on Standard Air Density of 0.075 Lb/ft³ @ 70°F and 0 Ft elevation: 1.2 kg/m³ @ 21°C and 0 mt)

KCB-18



Especificaciones técnicas / Performance data

Diametro de Turbina = 18 9/16" Diametro de Descarga= 28" Area de Descarga = 4.276 Ft² RPM Max=Clase I 2058 Clase II 2717 Clase III 3204 Velocidad Tangencial (PPM)=4.86 X RPM BHP Max =0.8806 (RPM/1000)³												Wheel Diameter = 18 9/16" Outlet Diameter= 28" Outlet Area= 4.276 Ft² RPM Max=Clase I 2058 Clase II 2717 Clase III 3204 Tip speed (FPM)= 4.86 X RPM Max. BHP = 0.8806 (RPM/1000)³											
Caudal (Air Flow)		Velocidad Descarga (Outlet Velocity)	Presión Estática en Pulgadas C.A. (Static Pressure in Inches W. G.)																				
			0.25"		0.5"		0.75"		1"		1.25"		1.5"		2"		2.5"		3"		3.5"		
CFM	M³/HR	FPM	RPM	BHP	RPM	BHP	RPM	BHP	RPM	BHP	RPM	BHP	RPM	BHP	RPM	BHP	RPM	BHP	RPM	BHP	RPM	BHP	
2566	4359	600	667	0.26	774	0.41	890	0.62	1004	0.89	1115	1.22	--	--	--	--	--	--	--	--	--	--	
2993	5085	700	744	0.36	835	0.51	930	0.71	1029	0.96	1128	1.26	1225	1.62	--	--	--	--	--	--	--	--	
3421	5812	800	824	0.49	905	0.65	986	0.84	1070	1.08	1156	1.36	1244	1.69	1414	2.49	--	--	--	--	--	--	
3848	6538	900	904	0.65	982	0.83	1052	1.02	1124	1.25	1199	1.52	1276	1.83	1430	2.57	1581	3.48	1725	4.52	--	--	
4276	7265	1000	987	0.85	1061	1.05	1124	1.25	1188	1.48	1253	1.73	1320	2.03	1459	2.73	1597	3.59	1733	4.59	1866	5.72	
4704	7991	1100	1071	1.08	1139	1.30	1201	1.53	1258	1.75	1315	2.00	1375	2.29	1498	2.96	1625	3.78	1751	4.73	1876	5.81	
5131	8718	1200	1156	1.36	1220	1.60	1279	1.84	1332	2.08	1385	2.34	1438	2.62	1548	3.27	1663	4.05	1778	4.95	1893	5.98	
5559	9444	1300	1242	1.69	1300	1.94	1358	2.21	1410	2.47	1459	2.73	1506	3.01	1606	3.65	1709	4.40	1815	5.26	1922	6.26	
5986	10171	1400	1329	2.07	1383	2.33	1438	2.62	1489	2.90	1534	3.18	1579	3.47	1670	4.10	1764	4.83	1861	5.67	1959	6.62	
6414	10897	1500	1418	2.51	1467	2.78	1518	3.08	1567	3.39	1613	3.69	1656	4.00	1739	4.63	1825	5.35	1913	6.17	2004	7.09	
6842	11624	1600	1507	3.02	1552	3.29	1600	3.61	1647	3.93	1692	4.26	1732	4.58	1812	5.24	1891	5.95	1972	6.75	2055	7.64	
7269	12350	1700	1595	3.57	1637	3.86	1683	4.19	1727	4.54	1771	4.89	1811	5.23	1887	5.91	1960	6.63	2036	7.43	2112	8.30	
7697	13077	1800	1679	4.16	1723	4.51	1765	4.84	1808	5.20	1851	5.58	1891	5.95	1964	6.67	2034	7.41	2103	8.20	2175	9.06	
8124	13803	1900	1763	4.83	1810	5.22	1850	5.57	1891	5.95	1930	6.33	1970	6.73	2042	7.50	2109	8.27	2175	9.06	2242	9.92	
8552	14530	2000	1867	5.73	1897	6.02	1935	6.38	1973	6.76	2012	7.17	2050	7.58	2120	8.39	2186	9.20	2249	10.01	2311	10.87	
9407	15983	2200	2035	7.42	2077	7.89	2106	8.23	2141	8.65	2176	9.07	2211	9.52	2280	10.43	2342	11.32	2402	12.20	2459	13.09	

Los números en negro representan la eficiencia Máxima

Bold figures Indicate maximum efficiency

Caudal (Air Flow)		Velocidad Descarga (Outlet Velocity)	Presión Estática en Pulgadas C.A. (Static Pressure in Inches W. G.)																			
			4"		4.5"		5"		5.5"		6"		6.5"		7"		7.5"		8"		8.5"	
CFM	M³/HR	FPM	RPM	BHP	RPM	BHP	RPM	BHP	RPM	BHP	RPM	BHP	RPM	BHP	RPM	BHP	RPM	BHP	RPM	BHP	RPM	BHP
5131	8718	1200	2008	7.13	2120	8.39	2230	9.76	--	--	--	--	--	--	--	--	--	--	--	--	--	--
5559	9444	1300	2029	7.35	2135	8.57	2239	9.88	2341	11.30	2442	12.82	--	--	--	--	--	--	--	--	--	--
5986	10171	1400	2058	7.67	2157	8.84	2256	10.11	2354	11.49	2450	12.95	2544	14.50	2638	16.16	--	--	--	--	--	--
6414	10897	1500	2095	8.10	2188	9.22	2281	10.44	2373	11.77	2465	13.18	2555	14.69	2645	16.29	2733	17.98	2820	19.74	--	--
6842	11624	1600	2140	8.63	2226	9.71	2313	10.90	2400	12.17	2487	13.54	2573	15.00	2659	16.55	2743	18.18	2827	19.89	2909	21.69
7269	12350	1700	2191	9.26	2272	10.32	2352	11.46	2434	12.69	2515	14.01	2598	15.44	2680	16.94	2760	18.52	2841	20.19	2920	21.93
7697	13077	1800	2248	10.00	2322	11.03	2398	12.14	2475	13.34	2551	14.62	2629	16.00	2706	17.46	2783	18.98	2860	20.59	2936	22.29
8124	13803	1900	2309	10.85	2379	11.86	2450	12.95	2521	14.11	2593	15.35	2667	16.70	2739	18.10	2813	19.60	2886	21.16	2959	22.82
8552	14530	2000	2375	11.80	2440	12.79	2506	13.87	2573	15.00	2641	16.22	2709	17.51	2779	18.90	2848	20.34	2917	21.86	2987	23.47
10262	17436	2400	2515	14.01	2573	15.00	2632	16.05	2690	17.15	2750	18.32	2811	19.56	2873	20.87	2935	22.27	2997	23.70	3061	25.25
11118	18889	2600	2665	16.66	2717	17.67	2770	18.72	2823	19.81	2876	20.94	2930	22.16	2985	23.42	3041	24.76	3096	26.14	3153	27.61
10262	17436	2400	2820	19.74	2869	20.79	2916	21.84	2965	22.96	3013	24.08	3063	25.30	3111	26.52	3161	27.82	--	--	--	--
11973	20342	2800	2976	23.21	3024	24.35	3070	25.47	3114	26.60	3159	27.76	3204	28.96	--	--	--	--	--	--	--	--

Los números en negro representan la eficiencia Máxima

Bold figures Indicate maximum efficiency

Ventiladores Clase I
 Ventiladores Clase II
 Ventiladores Clase III

Class I Fans
 Class II Fans
 Class III Fans

Curvas de operación Operation curves

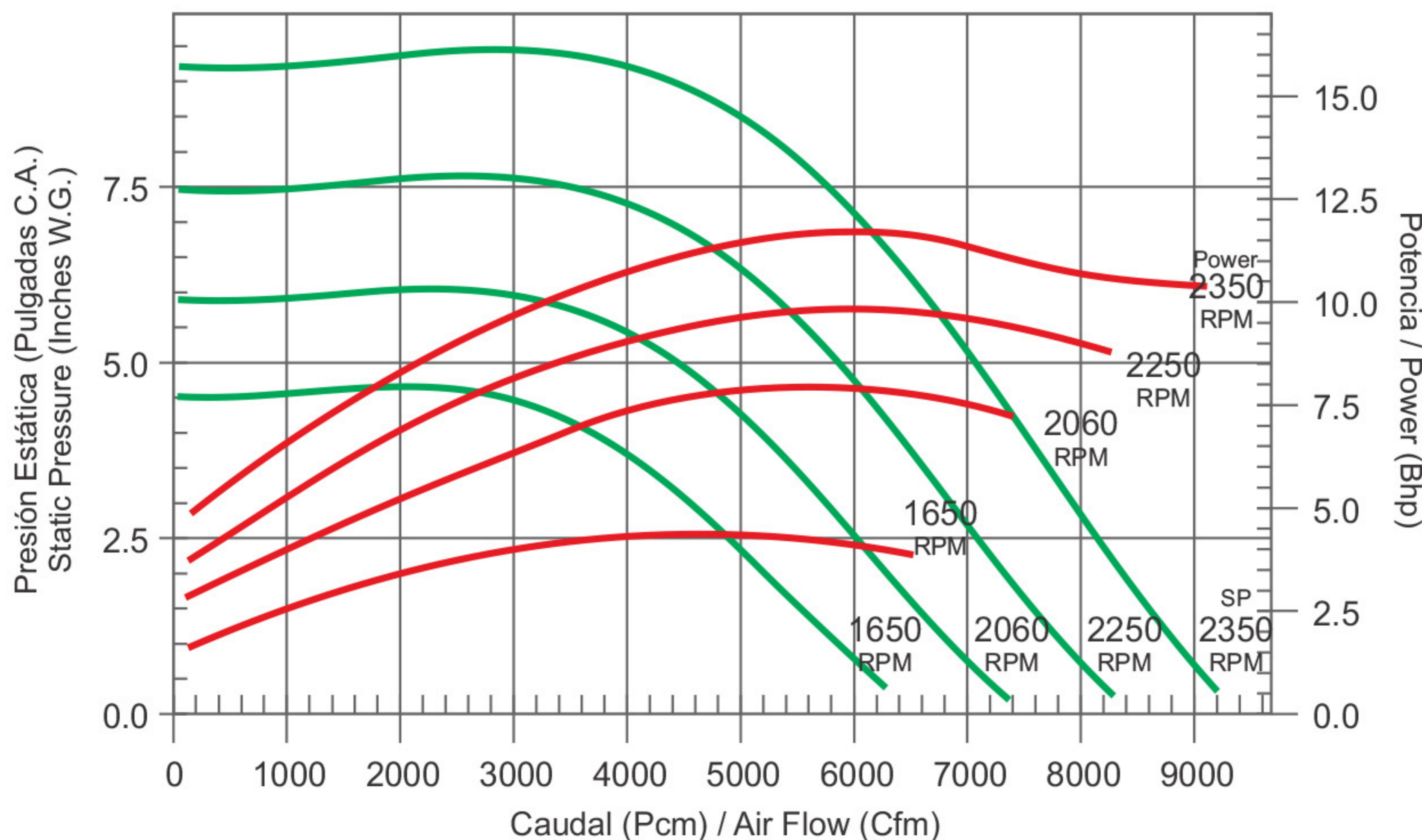

Espectros de potencia sonora Sound Power level ratings

	Freq.	63	125	250	500	1000	2000	4000	8000	Total	Hz
1650	LwA	85	86	84	79	76	75	70	62	90	dB(A)
2060	LwA	89	87	88	85	81	80	76	68	94	dB(A)
2250	LwA	90	87	88	87	82	81	78	71	95	dB(A)
2350	LwA	91	88	88	88	83	82	79	72	96	dB(A)

Datos obtenidos de acuerdo a la norma AMCA estándar 301
(Information obtained according to the AMCA Standard 301)

Todas las capacidades están basadas en la Densidad Estándar de Aire de 0.075 Lb/ft³ @ 70°F y 0 pies de Elevación: 1.2 kg/m³ @ 21°C y 0 mt
(All Capacities are based on Standard Air Density of 0.075 Lb/ft³ @ 70°F and 0 Ft elevation: 1.2 kg/m³ @ 21°C and 0 mt)

KCB-20



Especificaciones técnicas / Performance data

Diametro de Turbina = 20 7/16" Diametro de Descarga= 31" Area de Descarga = 5.241 Ft ² RPM Max=Clase I [2007] Clase II [2448] Clase III [2709] Velocidad Tangencial (PPM)=5.35 X RPM BHP Max = 1.3471 (RPM/1000) ³												Wheel Diameter = 20 7/16" Outlet Diameter= 31" Outlet Area= 5.241 Ft ² RPM Max=Clase I [2007] Clase II [2448] Clase III [2709] Tip speed (FPM)= 5.35 X RPM Max. BHP = 1.3471 (RPM/1000) ³											
Caudal (Air Flow)		Velocidad Descarga (Outlet Velocity)	Presión Estática en Pulgadas C.A. (Static Pressure in Inches W. G.)																				
			0.25"		0.5"		0.75"		1"		1.25"		1.5"		2"		2.5"		3"		3.5"		
CFM	M ³ /HR	FPM	RPM	BHP	RPM	BHP	RPM	BHP	RPM	BHP	RPM	BHP	RPM	BHP	RPM	BHP	RPM	BHP	RPM	BHP	RPM	BHP	
3145	5343	600	597	0.29	694	0.45	796	0.68	900	0.98	998	1.34	--	--	--	--	--	--	--	--	--	--	
3669	6233	700	666	0.40	748	0.56	833	0.78	922	1.06	1011	1.39	1097	1.78	--	--	--	--	--	--	--	--	
4193	7124	800	738	0.54	812	0.72	883	0.93	958	1.19	1037	1.50	1114	1.86	1266	2.73	--	--	--	--	--	--	
4717	8014	900	810	0.72	879	0.92	943	1.13	1007	1.38	1075	1.67	1143	2.01	1281	2.83	1417	3.83	1547	4.98	--	--	
5241	8904	1000	884	0.93	950	1.15	1007	1.38	1064	1.62	1123	1.91	1183	2.23	1307	3.01	1431	3.95	1553	5.05	1672	6.29	
5765	9795	1100	959	1.19	1021	1.43	1076	1.68	1127	1.93	1179	2.21	1232	2.52	1342	3.26	1456	4.16	1569	5.20	1680	6.39	
6289	10685	1200	1036	1.50	1093	1.76	1146	2.03	1194	2.29	1241	2.57	1289	2.88	1387	3.60	1490	4.46	1593	5.45	1697	6.58	
6813	11576	1300	1113	1.86	1166	2.13	1217	2.43	1263	2.72	1306	3.00	1350	3.32	1439	4.02	1532	4.84	1627	5.80	1722	6.88	
7337	12466	1400	1191	2.28	1240	2.57	1289	2.88	1334	3.20	1375	3.50	1416	3.82	1497	4.52	1580	5.31	1667	6.24	1755	7.28	
7862	13357	1500	1271	2.77	1314	3.06	1360	3.39	1404	3.73	1445	4.06	1483	4.39	1558	5.10	1635	5.88	1714	6.78	1795	7.79	
8386	14247	1600	1351	3.32	1390	3.62	1433	3.97	1476	4.33	1515	4.69	1552	5.04	1623	5.76	1694	6.55	1766	7.42	1842	8.41	
8910	15138	1700	1429	3.93	1466	4.25	1508	4.62	1548	4.99	1587	5.38	1623	5.76	1690	6.50	1757	7.30	1824	8.18	1892	9.13	
9434	16028	1800	1504	4.58	1544	4.96	1582	5.33	1620	5.73	1658	6.14	1693	6.54	1760	7.34	1812	8.02	1885	9.02	1949	9.97	
9958	16918	1900	1580	5.31	1622	5.75	1658	6.14	1694	6.55	1730	6.98	1764	7.40	1829	8.24	1890	9.09	1949	9.97	2009	10.92	
10482	17809	2000	1673	6.30	1700	6.62	1734	7.03	1767	7.44	1803	7.89	1837	8.35	1900	9.24	1959	10.13	2015	11.01	2071	11.97	
11530	19590	2200	1848	8.51	1860	8.67	1888	9.06	1919	9.52	1950	9.99	1981	10.48	2042	11.47	2099	12.45	2151	13.41	2203	14.41	

Los números en negro representan la eficiencia Máxima

Bold figures Indicate maximum efficiency

Caudal (Air Flow)		Velocidad Descarga (Outlet Velocity)	Presión Estática en Pulgadas C.A. (Static Pressure in Inches W. G.)																			
			4"		4.5"		5"		5.5"		6"		6.5"		7"		7.5"		8"		8.5"	
CFM	M ³ /HR	FPM	RPM	BHP	RPM	BHP	RPM	BHP	RPM	BHP	RPM	BHP	RPM	BHP	RPM	BHP	RPM	BHP	RPM	BHP	RPM	BHP
6289	10685	1200	1800	7.85	1900	9.24	1998	10.74	2093	12.35	--	--	--	--	--	--	--	--	--	--	--	--
6813	11576	1300	1818	8.10	1913	9.43	2007	10.89	2098	12.43	2188	14.10	2275	15.87	--	--	--	--	--	--	--	--
7337	12466	1400	1844	8.44	1933	9.74	2021	11.13	2109	12.64	2195	14.25	2280	15.97	2363	17.78	2444	19.68	--	--	--	--
7862	13357	1500	1878	8.92	1961	10.16	2044	11.50	2126	12.94	2208	14.50	2290	16.18	2370	17.94	2448	19.77	2527	21.73	2603	23.75
8386	14247	1600	1918	9.50	1995	10.70	2072	11.99	2150	13.40	2229	14.91	2306	16.51	2382	18.20	2458	20.01	2533	21.90	2607	23.86
8910	15138	1700	1964	10.20	2035	11.35	2107	12.61	2181	13.97	2254	15.43	2327	16.98	2400	18.63	2473	20.37	2545	22.21	2616	24.13
9434	16028	1800	2015	11.01	2081	12.14	2148	13.36	2217	14.68	2286	16.10	2356	17.61	2425	19.21	2493	20.88	2563	22.67	2631	24.54
9958	16918	1900	2069	11.94	2132	13.05	2194	14.23	2259	15.53	2323	16.89	2389	18.36	2454	19.91	2520	21.55	2585	23.27	2651	25.09
10482	17809	2000	2128	12.98	2187	14.08	2245	15.25	2306	16.51	2366	17.85	2428	19.28	2489	20.78	2552	22.39	2614	24.07	2676	25.81
11530	19590	2200	2254	15.43	2306	16.51	2358	17.65	2410	18.86	2464	20.15	2519	21.52	2574	22.98	2630	24.51	2686	26.10	--	--
12578	21371	2400	2388	18.34	2435	19.44	2482	20.59	2528	21.78	2577	23.06	2625	24.37	2675	25.79	--	--	--	--	--	--
13627	23152	2600	2527	21.73	2570	22.88	2613	24.05	2656	25.25	2699	26.50	--	--	--	--	--	--	--	--	--	--
14675	24932	2800	2667	25.56	2709	26.79	--	--	--	--	--	--	--	--	--	--	--	--	--	--	--	--

Los números en negro representan la eficiencia Máxima

Bold figures Indicate maximum efficiency

 Ventiladores Clase I
 Ventiladores Clase II
 Ventiladores Clase III

 Class I Fans
 Class II Fans
 Class III Fans

Curvas de operación Operation curves

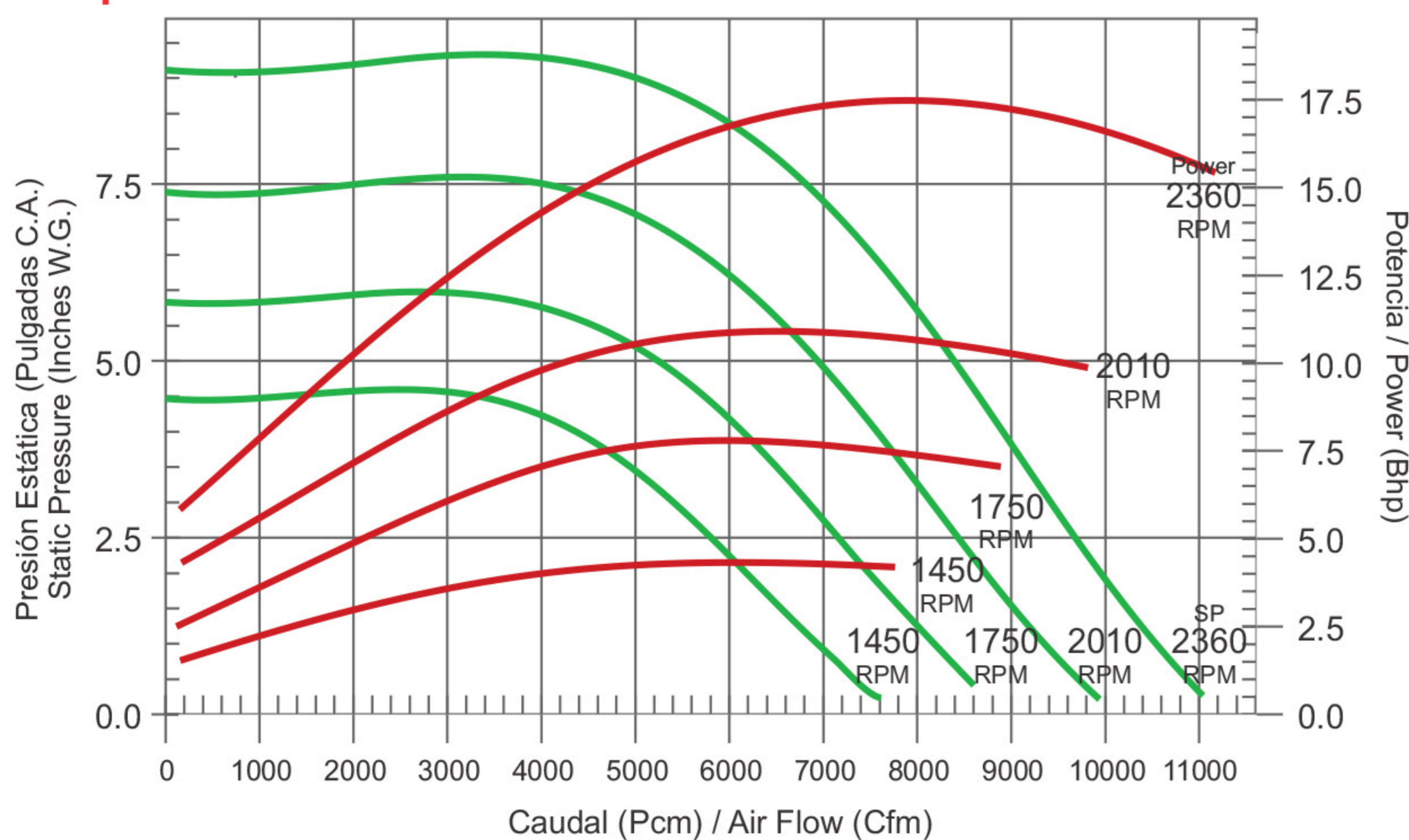

Espectros de potencia sonora Sound Power level ratings

Revoluciones por minuto (RPM)	Freq.	Power (dB(A))								Total	Hz
		63	125	250	500	1000	2000	4000	8000		
1450	LwA	83	82	86	80	79	77	73	67	90	dB(A)
1750	LwA	86	84	92	85	83	82	78	73	95	dB(A)
2010	LwA	89	87	94	90	87	85	83	77	98	dB(A)
2360	LwA	92	91	96	96	91	89	87	82	101	dB(A)

Datos obtenidos de acuerdo a la norma AMCA estándar 301
(Information obtained according to the AMCA Standard 301)

Todas las capacidades están basadas en la Densidad Estándar de Aire de 0.075 Lb/ft³ @ 70°F y 0 pies de Elevación: 1.2 kg/m³ @ 21°C y 0 mt
(All Capacities are based on Standard Air Density of 0.075 Lb/ft³ @ 70°F and 0 Ft elevation: 1.2 kg/m³ @ 21°C and 0 mt)

KCB-22



Especificaciones técnicas / Performance data

Diametro de Turbina = 22 9/16"	Wheel Diameter = 22 9/16"
Diametro de Descarga= 34"	Outlet Diameter= 34"
Area de Descarga = 6.305 Ft ²	Outlet Area= 6.305 Ft ²
RPM Max=Clase I 1682 Clase II 2298 Clase III 2444	RPM Max=Clase I 1682 Clase II 2298 Clase III 2444
Velocidad Tangencial (PPM)=5.907 X RPM	Tip speed (FPM)= 5.907 X RPM
BHP Max =1.495 (RPM/1000) ³	Max. BHP = 1.495 (RPM/1000) ³

Caudal (Air Flow)		Velocidad Descarga (Outlet Velocity)	Presión Estática en Pulgadas C.A. (Static Pressure in Inches W. G.)																			
			0.25"		0.5"		0.75"		1"		1.25"		1.5"		2"		2.5"		3"		3.5"	
CFM	M ³ /HR	FPM	RPM	BHP	RPM	BHP	RPM	BHP	RPM	BHP	RPM	BHP	RPM	BHP	RPM	BHP	RPM	BHP	RPM	BHP	RPM	BHP
3783	6427	600	523	0.21	618	0.35	716	0.55	808	0.79	897	1.08	--	--	--	--	--	--	--	--	--	--
4414	7499	700	582	0.29	661	0.43	745	0.62	828	0.85	909	1.12	986	1.43	--	--	--	--	--	--	--	--
5044	8570	800	645	0.40	712	0.54	785	0.72	857	0.94	930	1.20	1001	1.50	1137	2.20	--	--	--	--	--	--
5675	9641	900	710	0.53	769	0.68	831	0.86	895	1.07	960	1.32	1025	1.61	1151	2.28	1273	3.08	--	--	--	--
6305	10712	1000	778	0.70	829	0.85	883	1.03	941	1.24	998	1.49	1057	1.77	1173	2.41	1287	3.18	1396	4.07	--	--
6936	11783	1100	845	0.90	892	1.06	941	1.24	990	1.45	1043	1.70	1096	1.97	1202	2.60	1308	3.34	1410	4.19	1509	5.14
7566	12855	1200	914	1.14	957	1.31	1000	1.50	1045	1.71	1092	1.95	1139	2.21	1237	2.83	1334	3.55	1431	4.38	1525	5.30
8197	13926	1300	983	1.42	1023	1.60	1063	1.80	1104	2.01	1145	2.25	1189	2.51	1278	3.12	1368	3.83	1458	4.63	1546	5.53
8827	14997	1400	1052	1.74	1090	1.93	1127	2.14	1164	2.36	1202	2.60	1242	2.86	1322	3.46	1406	4.15	1489	4.94	1573	5.82
9458	16068	1500	1122	2.11	1157	2.32	1192	2.53	1227	2.76	1262	3.00	1298	3.27	1372	3.86	1449	4.55	1526	5.32	1605	6.18
10088	17140	1600	1190	2.52	1225	2.75	1258	2.97	1291	3.21	1323	3.47	1356	3.73	1425	4.32	1495	5.00	1568	5.76	1642	6.61
10719	18211	1700	1260	2.99	1295	3.24	1324	3.47	1355	3.72	1386	3.98	1417	4.25	1481	4.85	1546	5.53	1613	6.27	1681	7.11
11349	19282	1800	1328	3.50	1363	3.79	1392	4.03	1421	4.29	1450	4.55	1479	4.83	1538	5.44	1599	6.11	1661	6.86	1726	7.69
11980	20353	1900	1399	4.09	1433	4.40	1460	4.65	1487	4.92	1514	5.19	1542	5.48	1598	6.10	1655	6.77	1713	7.52	1773	8.33
12610	21424	2000	1470	4.74	1502	5.07	1528	5.34	1554	5.61	1580	5.90	1607	6.20	1649	6.70	1712	7.50	1767	8.25	1823	9.05
13871	23567	2200	1612	6.26	1641	6.60	1666	6.92	1690	7.22	1713	7.52	1737	7.84	1785	8.50	1832	9.20	1881	9.95	1931	10.76

Los números en negro representan la eficiencia Máxima

Bold figures Indicate maximum efficiency

Caudal (Air Flow)		Velocidad Descarga (Outlet Velocity)	Presión Estática en Pulgadas C.A. (Static Pressure in Inches W. G.)																			
			4"		4.5"		5"		5.5"		6"		6.5"		7"		7.5"		8"		8.5"	
CFM	M ³ /HR	FPM	RPM	BHP	RPM	BHP	RPM	BHP	RPM	BHP	RPM	BHP	RPM	BHP	RPM	BHP	RPM	BHP	RPM	BHP	RPM	BHP
7566	12855	1200	1617	6.32	1706	7.43	1794	8.63	--	--	--	--	--	--	--	--	--	--	--	--	--	--
8197	13926	1300	1634	6.52	1719	7.60	1803	8.76	1884	10.00	--	--	--	--	--	--	--	--	--	--	--	--
8827	14997	1400	1656	6.78	1737	7.84	1817	8.96	1895	10.18	1972	11.46	2047	12.83	--	--	--	--	--	--	--	--
9458	16068	1500	1682	7.12	1760	8.15	1836	9.26	1911	10.43	1985	11.69	2057	13.02	2129	14.42	2199	15.91	--	--	--	--
10088	17140	1600	1714	7.53	1788	8.54	1860	9.63	1932	10.78	2003	12.01	2072	13.30	2141	14.67	2208	16.10	2276	17.63	2342	19.19
10719	18211	1700	1751	8.03	1820	9.01	1888	10.06	1957	11.20	2024	12.40	2091	13.67	2158	15.02	2223	16.43	2287	17.88	2352	19.44
11349	19282	1800	1791	8.58	1855	9.55	1921	10.60	1986	11.70	2050	12.88	2114	14.12	2178	15.44	2241	16.83	2303	18.26	2364	19.76
11980	20353	1900	1833	9.21	1895	10.18	1957	11.20	2018	12.29	2080	13.45	2142	14.69	2202	15.97	2263	17.33	2323	18.73	2382	20.21
12610	21424	2000	1880	9.94	1938	10.88	1997	11.90	2055	12.98	2114	14.12	2173	15.33	2231	16.61	2289	17.93	2347	19.32	2404	20.78
13871	23567	2200	1982	11.63	2032	12.55	2085	13.55	2138	14.61	2190	15.71	2244	16.90	2298	18.14	2351	19.41	2404	20.78	--	--
15132	25709	2400	2091	13.67	2137	14.58	2183	15.56	2231	16.61	2279	17.69	2328	18.85	2376	20.06	2425	21.32	--	--	--	--
16393	27852	2600	2207	16.08	2249	17.01	2291	17.97	2334	19.00	2377	20.09	2421	21.22	--	--	--	--	--	--	--	--
17654	29994	2800	2329	18.88	2366	19.81	2404	20.78	2444	21.82	--	--	--	--	--	--	--	--	--	--	--	--

Los números en negro representan la eficiencia Máxima

Bold figures Indicate maximum efficiency

Ventiladores Clase I
 Ventiladores Clase II
 Ventiladores Clase III

Class I Fans
 Class II Fans
 Class III Fans

Curvas de operación Operation curves

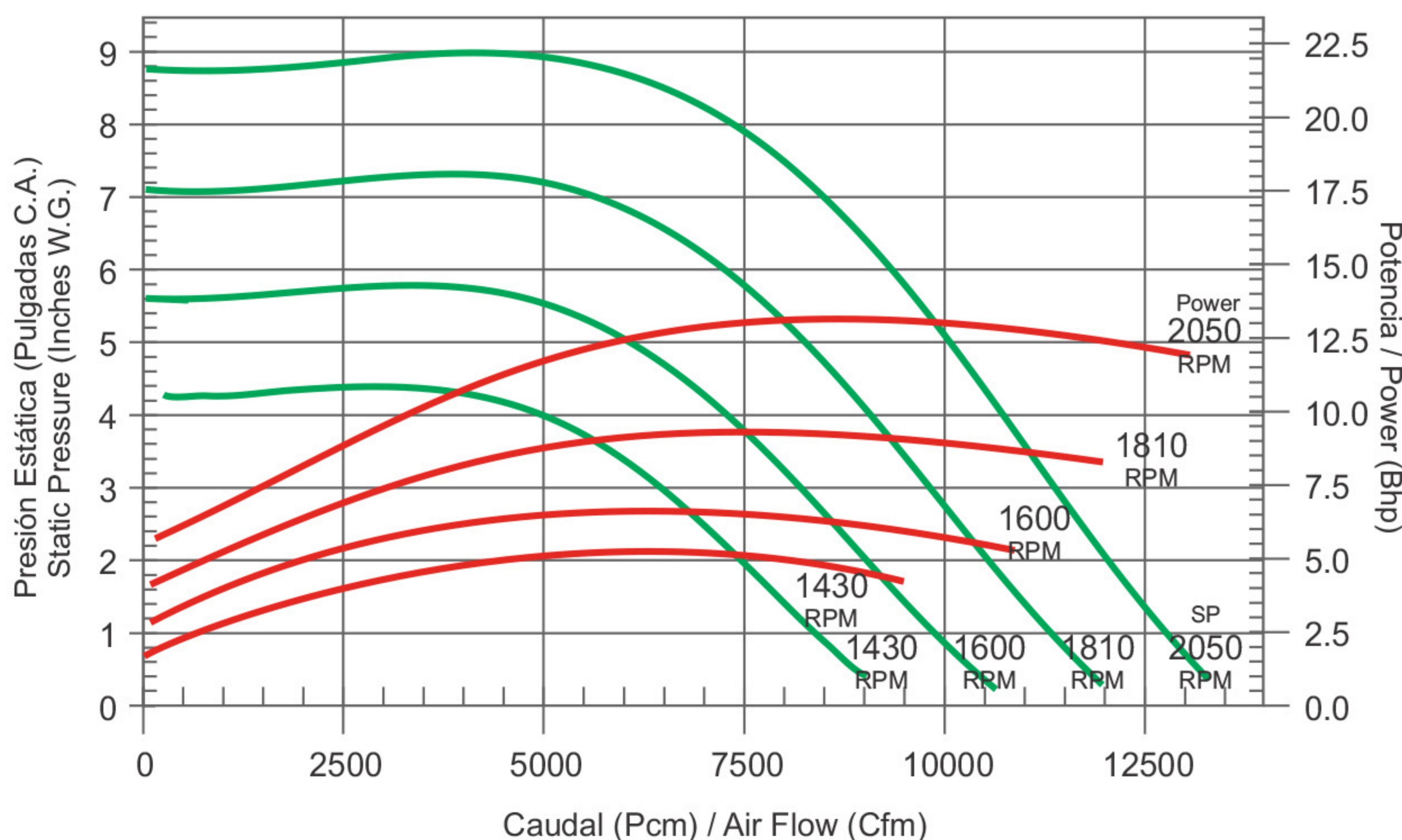

Todas las capacidades están basadas en la Densidad Estándar de Aire de 0.075 Lb/ft³ @ 70°F y 0 pies de Elevación: 1.2 kg/m³ @ 21°C y 0 mt
(All Capacities are based on Standard Air Density of 0.075 Lb/ft³ @ 70°F and 0 Ft elevation: 1.2 kg/m³ @ 21°C and 0 mt)

Espectros de potencia sonora Sound Power level ratings

	Freq.	63	125	250	500	1000	2000	4000	8000	Total	Hz
1430	LwA	82	82	86	80	78	77	73	67	90	dB(A)
1600	LwA	84	83	90	83	81	80	76	70	93	dB(A)
1810	LwA	87	85	93	86	84	83	79	74	95	dB(A)
2050	LwA	90	88	95	91	88	86	83	78	98	dB(A)

Datos obtenidos de acuerdo a la norma AMCA estándar 301
(Information obtained according to the AMCA Standard 301)

KCB-24



Especificaciones técnicas / Performance data

Diametro de Turbina = 24 5/8"	Wheel Diameter = 24 5/8"
Diametro de Descarga= 37"	Outlet Diameter= 37"
Area de Descarga = 7.467 Ft²	Outlet Area= 7.467 Ft²
RPM Max=Clase I 1540 Clase II 2053 Clase III 2240	RPM Max=Clase I 1540 Clase II 2053 Clase III 2240
Velocidad Tangencial (PPM)=6.447 X RPM	Tip speed (FPM)= 6.447 X RPM
BHP Max = 2.55 (RPM/1000)³	Max. BHP = 2.55 (RPM/1000)³

Caudal (Air Flow)		Velocidad Descarga (Outlet Velocity)	Presión Estática en Pulgadas C.A. (Static Pressure in Inches W. G.)																			
			0.25"		0.5"		0.75"		1"		1.25"		1.5"		2"		2.5"		3"		3.5"	
CFM	M³/HR	FPM	RPM	BHP	RPM	BHP	RPM	BHP	RPM	BHP	RPM	BHP	RPM	BHP	RPM	BHP	RPM	BHP	RPM	BHP	RPM	BHP
4480	7612	600	471	0.27	558	0.44	645	0.68	730	0.99	809	1.35	--	--	--	--	--	--	--	--	--	--
5227	8881	700	526	0.37	597	0.54	672	0.77	747	1.06	820	1.41	890	1.80	--	--	--	--	--	--	--	--
5974	10149	800	582	0.50	643	0.68	707	0.90	773	1.18	839	1.50	903	1.88	1026	2.76	--	--	--	--	--	--
6720	11418	900	641	0.67	693	0.85	750	1.07	808	1.35	866	1.66	925	2.02	1039	2.86	1148	3.86	--	--	--	--
7467	12686	1000	701	0.88	749	1.07	797	1.29	849	1.56	901	1.86	953	2.21	1059	3.03	1161	3.99	1259	5.09	1354	6.33
8214	13955	1100	763	1.13	805	1.33	849	1.56	894	1.82	940	2.12	989	2.47	1085	3.25	1179	4.18	1272	5.25	1362	6.45
8960	15224	1200	825	1.43	863	1.64	903	1.88	943	2.14	985	2.44	1028	2.77	1116	3.55	1204	4.45	1291	5.49	1376	6.64
9707	16492	1300	887	1.78	923	2.00	959	2.25	996	2.52	1033	2.81	1073	3.15	1153	3.91	1234	4.79	1315	5.80	1395	6.92
10454	17761	1400	949	2.18	983	2.42	1016	2.68	1050	2.95	1085	3.25	1120	3.58	1193	4.33	1268	5.20	1344	6.20	1419	7.29
11201	19030	1500	1012	2.64	1044	2.90	1076	3.17	1106	3.45	1138	3.76	1171	4.09	1238	4.84	1307	5.69	1377	6.66	1448	7.74
11947	20298	1600	1074	3.16	1105	3.44	1135	3.73	1165	4.03	1193	4.33	1221	4.64	1285	5.41	1349	6.26	1415	7.22	1481	8.28
12694	21567	1700	1136	3.74	1168	4.06	1195	4.35	1223	4.66	1251	4.99	1278	5.33	1336	6.07	1395	6.92	1455	7.86	1517	8.91
13441	22836	1800	1199	4.40	1230	4.74	1255	5.05	1282	5.37	1308	5.70	1335	6.06	1388	6.82	1442	7.65	1499	8.60	1557	9.62
14187	24104	1900	1261	5.12	1293	5.51	1317	5.82	1341	6.16	1366	6.50	1392	6.88	1441	7.63	1493	8.48	1546	9.42	1599	10.43
14934	25373	2000	1326	5.94	1355	6.35	1379	6.69	1403	7.04	1425	7.38	1449	7.76	1497	8.55	1545	9.40	1594	10.33	1645	11.34
16427	27910	2200	1454	7.84	1480	8.26	1503	8.67	1524	9.03	1546	9.42	1568	9.82	1610	10.64	1654	11.53	1697	12.46	1741	13.47

Los números en negro representan la eficiencia Máxima

Bold figures Indicate maximun efficiency

Caudal (Air Flow)		Velocidad Descarga (Outlet Velocity)	Presión Estática en Pulgadas C.A. (Static Pressure in Inches W. G.)																			
			4"		4.5"		5"		5.5"		6"		6.5"		7"		7.5"		8"		8.5"	
CFM	M³/HR	FPM	RPM	BHP	RPM	BHP	RPM	BHP	RPM	BHP	RPM	BHP	RPM	BHP	RPM	BHP	RPM	BHP	RPM	BHP	RPM	BHP
8960	15224	1200	1459	7.92	1540	9.31	1618	10.80	--	--	--	--	--	--	--	--	--	--	--	--	--	--
9707	16492	1300	1474	8.16	1551	9.51	1627	10.98	1700	12.53	1772	14.19	--	--	--	--	--	--	--	--	--	--
10454	17761	1400	1494	8.50	1567	9.81	1639	11.22	1710	12.75	1779	14.36	1847	16.07	1913	17.86	--	--	--	--	--	--
11201	19030	1500	1518	8.92	1587	10.20	1657	11.59	1724	13.06	1791	14.65	1856	16.31	1920	18.06	1984	19.93	2046	21.83	--	--
11947	20298	1600	1547	9.44	1613	10.70	1678	12.05	1742	13.49	1807	15.04	1870	16.67	1932	18.39	1992	20.17	2053	22.05	2112	24.02
12694	21567	1700	1579	10.05	1642	11.28	1704	12.62	1762	13.96	1826	15.54	1887	17.13	1946	18.79	2005	20.56	2064	22.41	2121	24.32
13441	22836	1800	1615	10.74	1674	11.97	1733	13.26	1792	14.67	1850	16.15	1907	17.70	1965	19.34	2022	21.08	2078	22.89	2134	24.77
14187	24104	1900	1655	11.55	1710	12.75	1765	14.03	1822	15.41	1877	16.86	1932	18.39	1987	20.02	2042	21.71	2096	23.48	2149	25.32
14934	25373	2000	1696	12.44	1748	13.63	1802	14.91	1854	16.25	1907	17.70	1960	19.19	2012	20.77	2065	22.44	2117	24.19	2168	25.99
16427	27910	2200	1788	14.57	1834	15.74	1881	16.96	1929	18.31	1977	19.69	2025	21.17	2072	22.70	2121	24.32	2169	26.03	2217	27.77
17921	30447	2400	1887	17.13	1928	18.28	1971	19.52	2013	20.80	2057	22.18	2100	23.62	2145	25.15	2188	26.71	2232	28.37	--	--
19414	32985	2600	1991	20.14	2029	21.30	2066	22.50	2106	23.82	2145	25.15	2185	26.60	2225	28.07	--	--	--	--	--	--
20908	35522	2800	2101	23.65	2135	24.80	2169	26.03	2205	27.33	2240	28.67	--	--	--	--	--	--	--	--	--	--

Los números en negro representan la eficiencia Máxima

Bold figures Indicate maximun efficiency

Ventiladores Clase I Ventiladores Clase II Ventiladores Clase III

Class I Fans Class II Fans Class III Fans

Curvas de operación / Operation curves

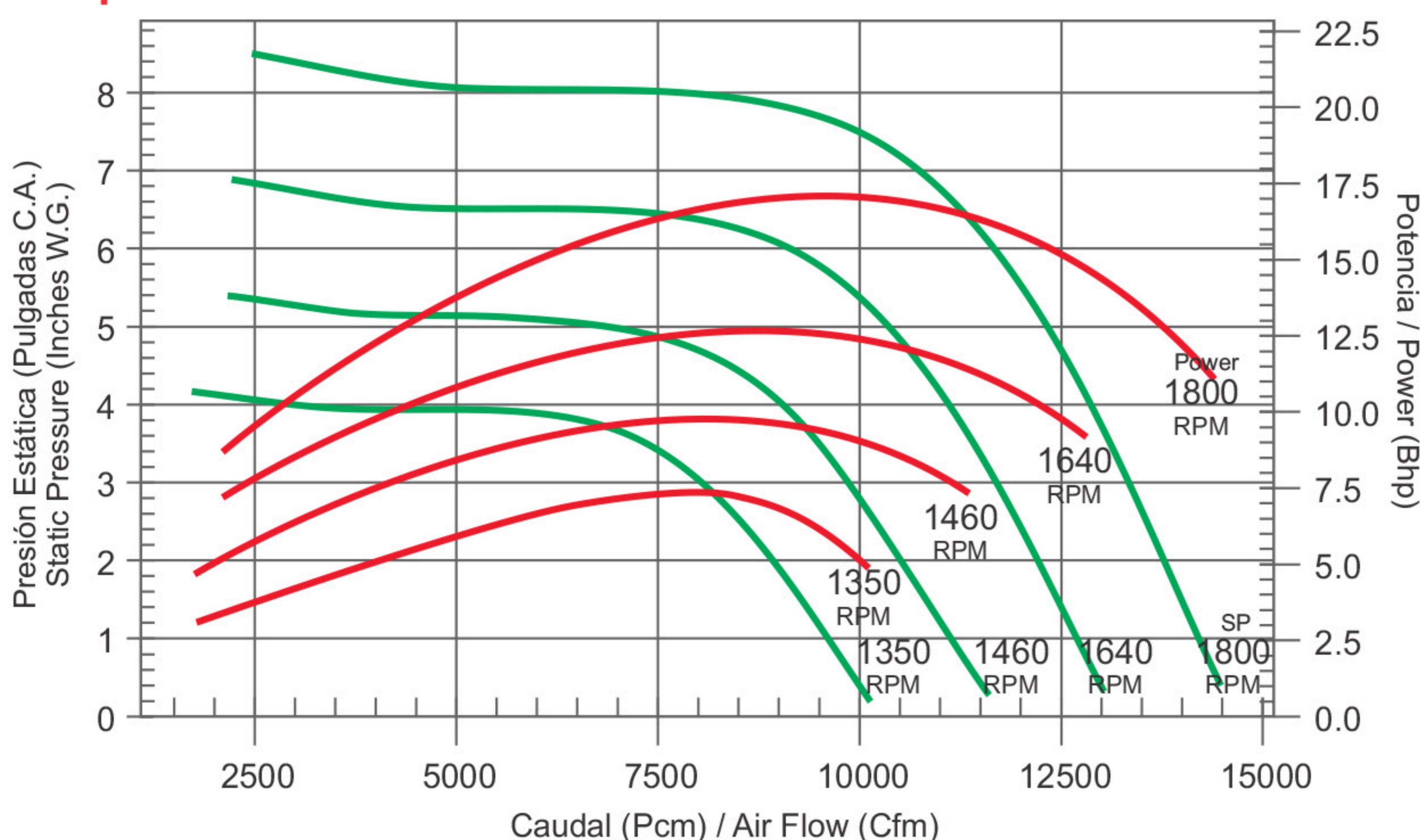

Espectros de potencia sonora / Sound Power level ratings

Revoluciones por minuto (RPM)	Freq.	63	125	250	500	1000	2000	4000	8000	Total	Hz
1350	LwA	85	85	86	82	80	78	74	68	91	dB(A)
1460	LwA	86	85	89	83	81	80	76	70	93	dB(A)
1640	LwA	87	86	93	86	84	83	79	74	96	dB(A)
1800	LwA	90	87	96	89	87	86	82	77	98	dB(A)

Datos obtenidos de acuerdo a la norma AMCA estándar 301 (Information obtained according to the AMCA Standard 301)

Todas las capacidades están basadas en la Densidad Estándar de Aire de 0.075 Lb/ft³ @ 70°F y 0 pies de Elevación: 1.2 kg/m³ @ 21°C y 0 mt
 (All Capacities are based on Standard Air Density of 0.075 Lb/ft³ @ 70°F and 0 Ft elevation: 1.2 kg/m³ @ 21°C and 0 mt)



Tipos de montaje y posiciones del motor / Mounting configurations

Montaje horizontal en piso / Horizontal floor mounted

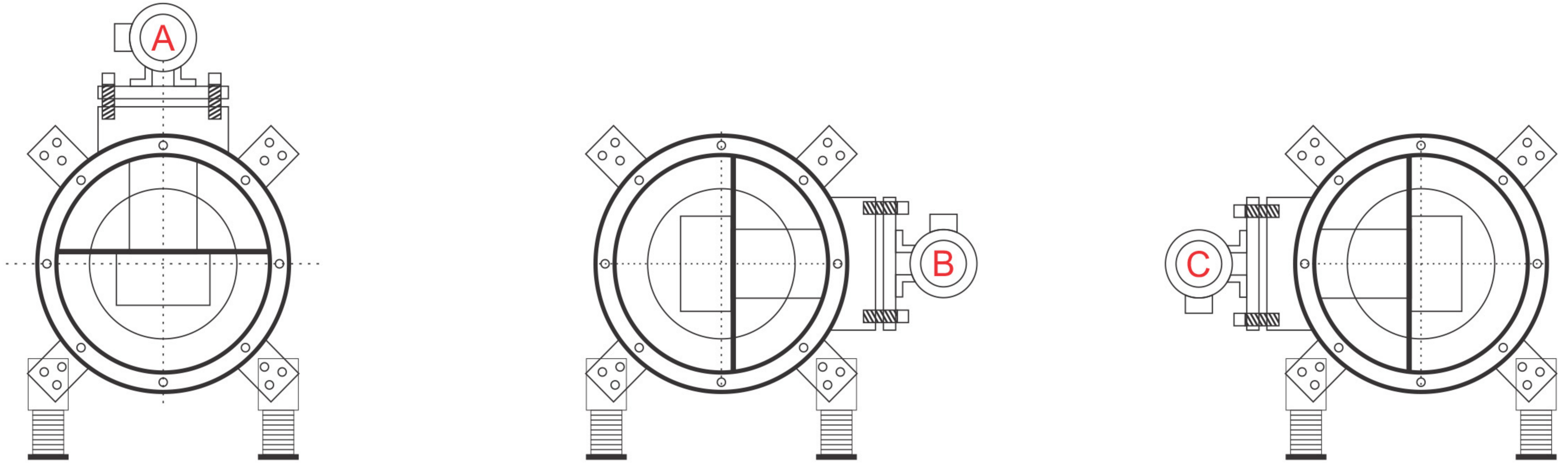

Montaje horizontal en techo tipo colgante / Horizontal ceiling hung

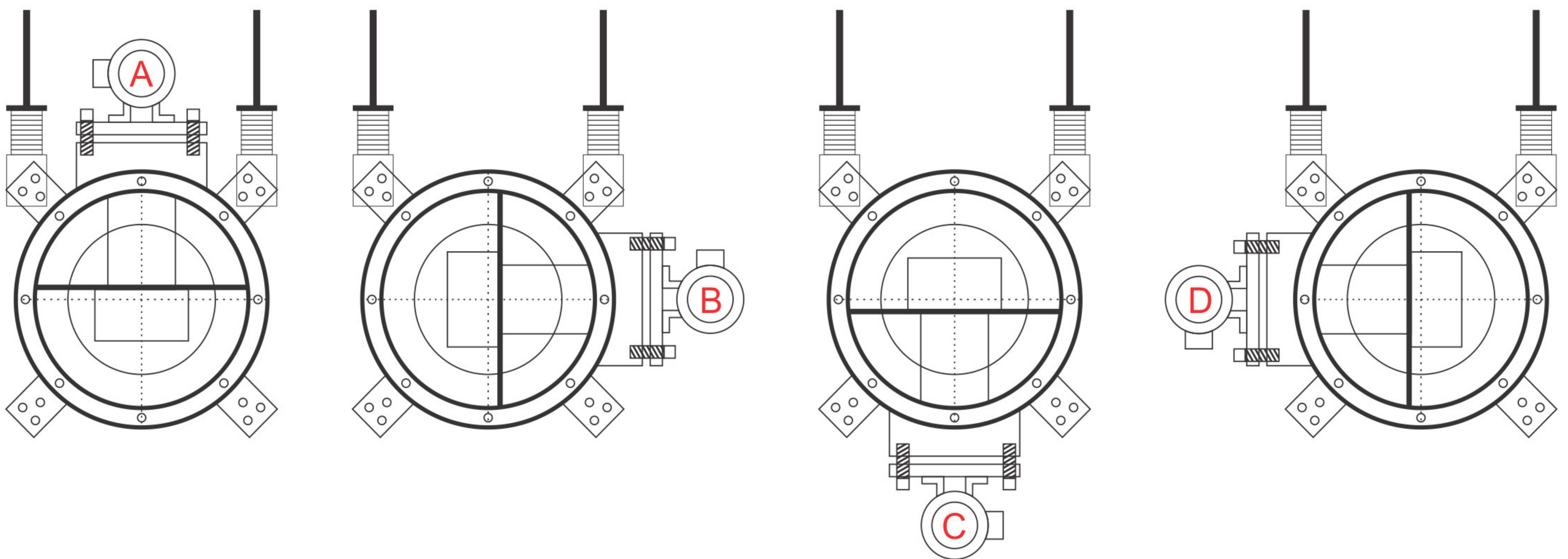

Montaje vertical en techo tipo colgante Vertical ceiling hung

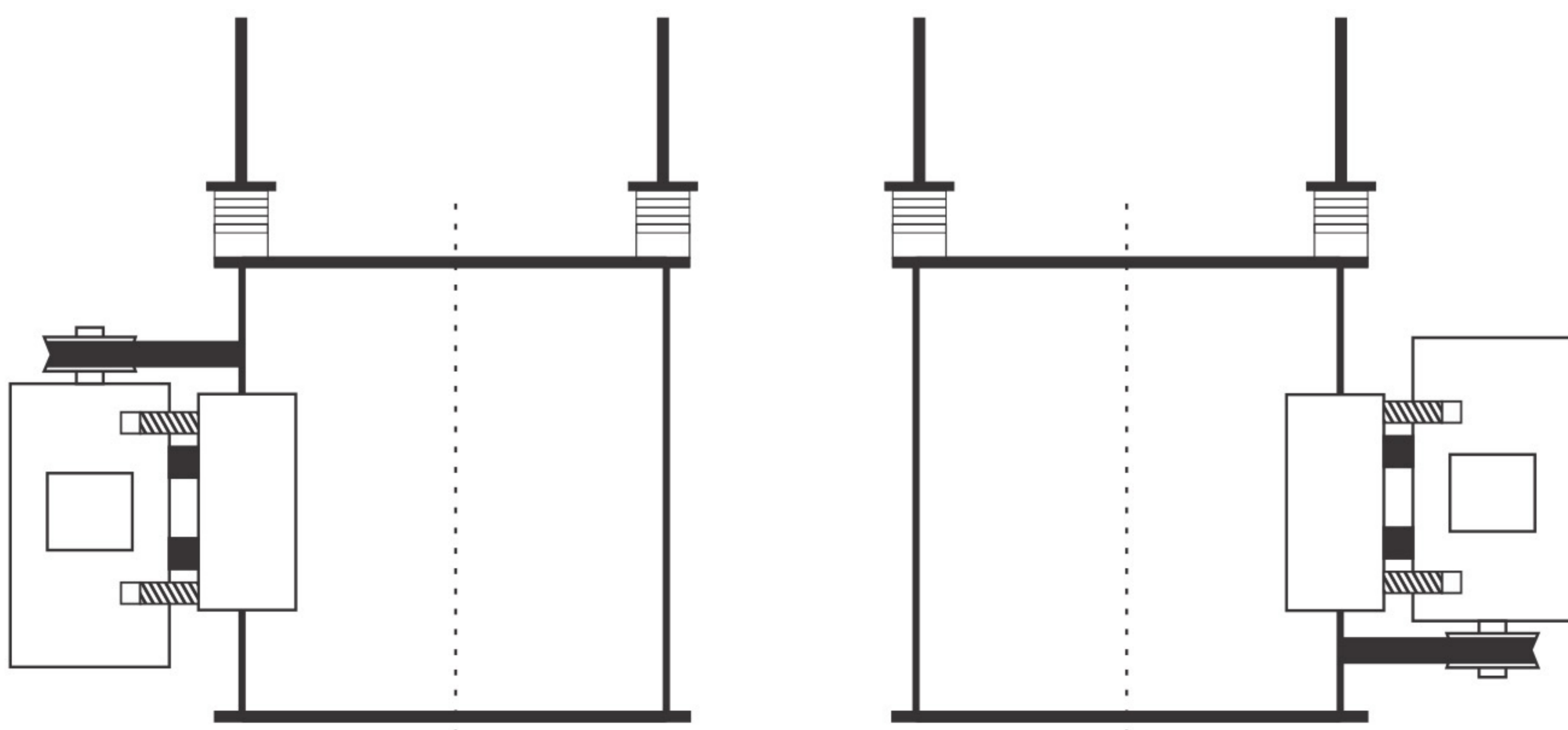

Montaje vertical en azotea Vertical roof mounted

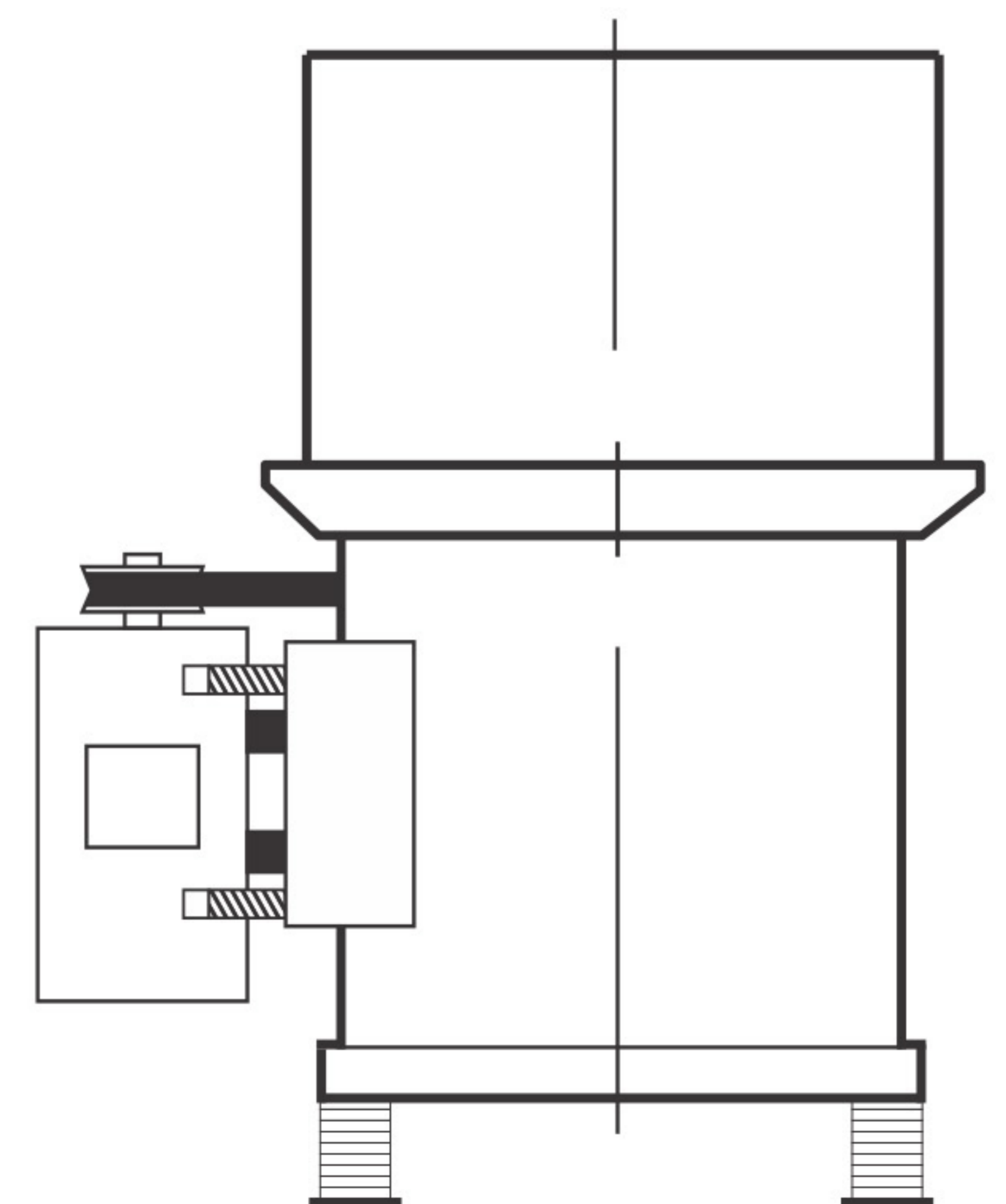

Dimensiones generales / Dimensions

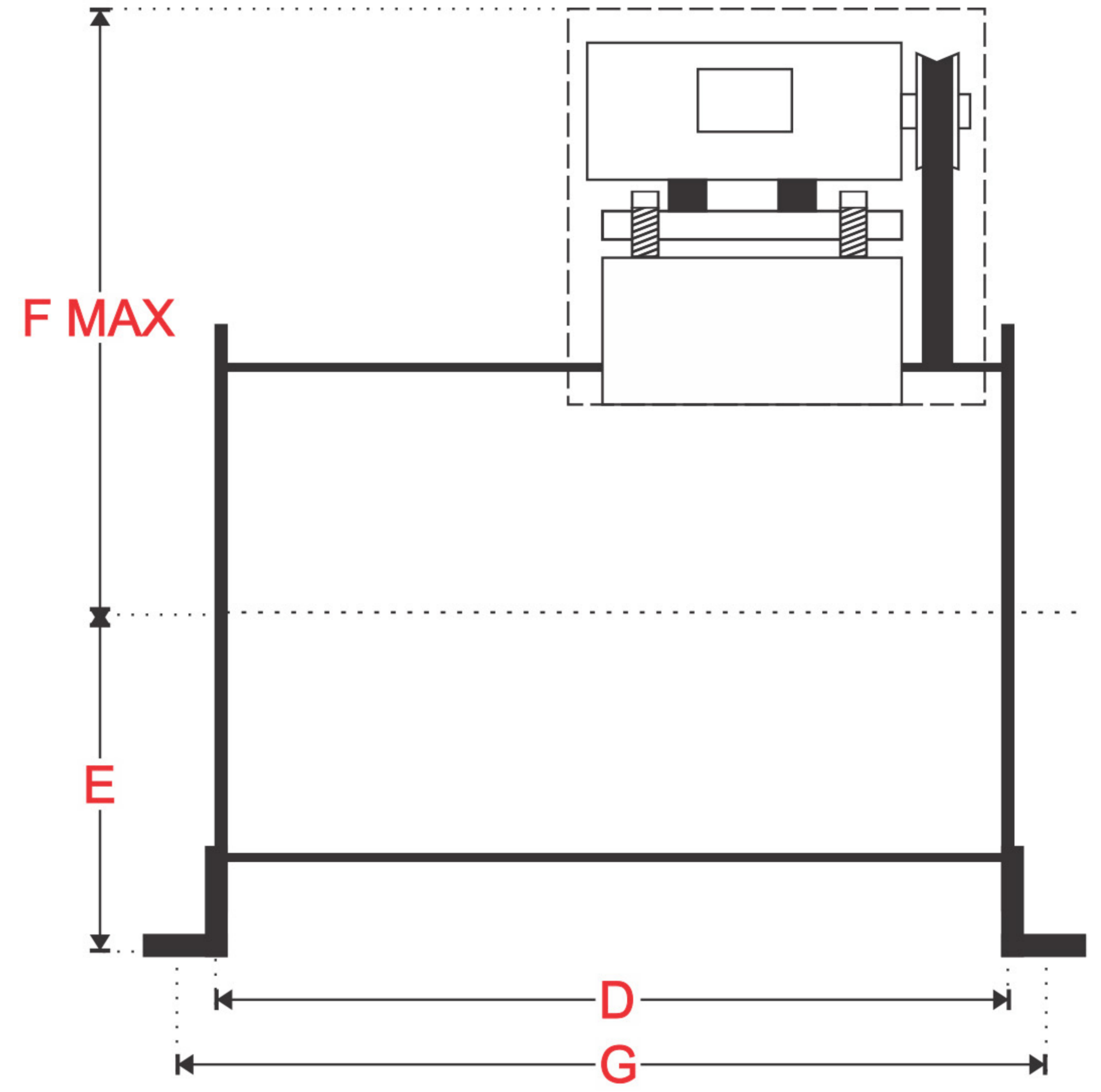
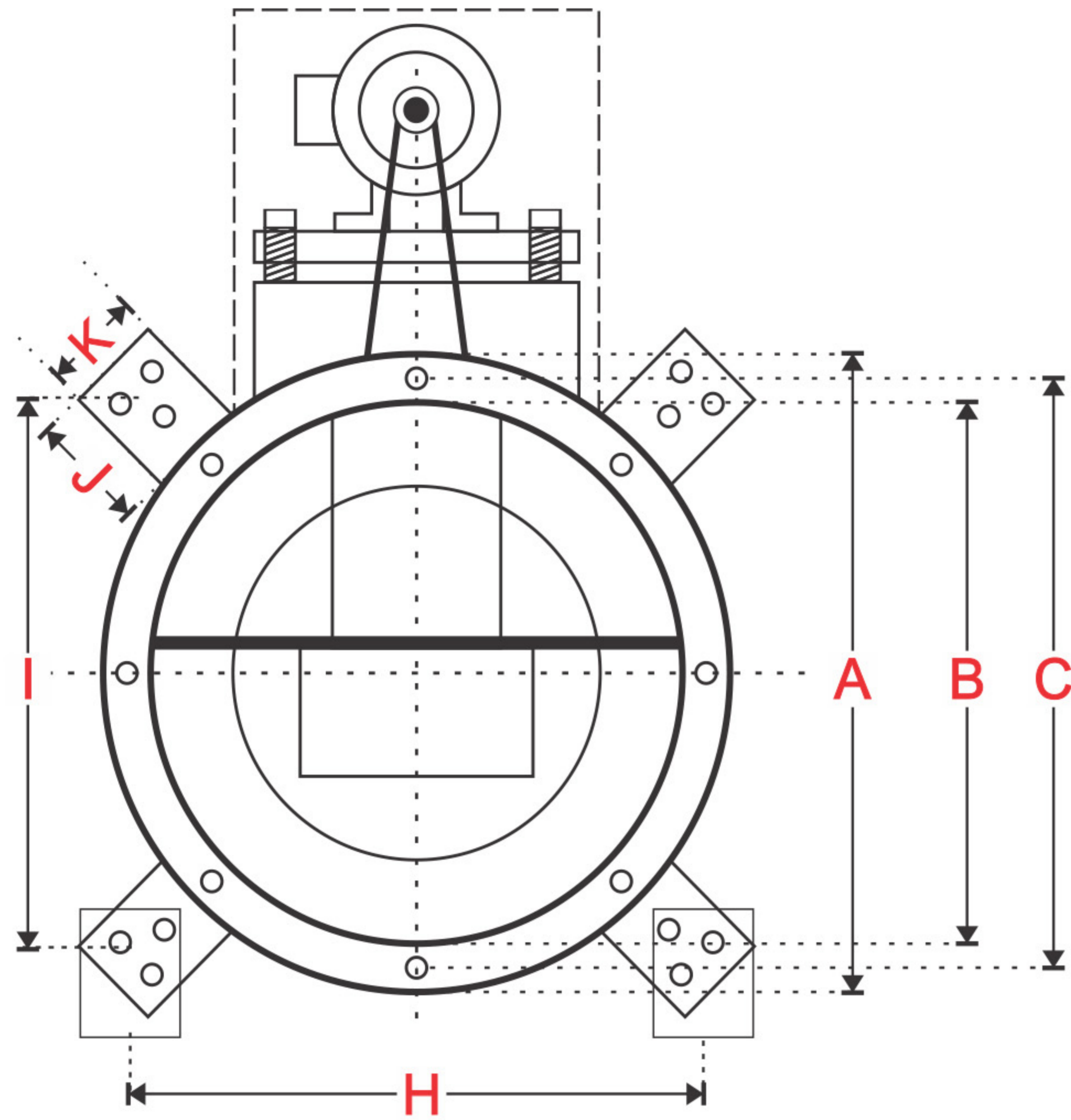

Modelo Model	Pulgadas (Inches)										
	A	B	C	D	E	F MAX	G	H	I	J	K
KCB-10	19	16	17 1/2	21	11	21	24	14 1/2	14 1/2	1 1/2	2 1/2
KCB-12	21	18	19 1/2	23	12	22	26	15 7/8	15 7/8	1 1/2	2 1/2
KCB-13	24	21	22 1/2	26	13 1/2	25 1/2	29	18	18	1 1/2	2 1/2
KCB-15	27	24	25 1/2	28	15 1/4	28 1/4	31	20 1/8	20 1/8	1 1/2	2 1/2
KCB-16	29	26	27 1/2	30	16 1/4	30 1/4	33	21 5/8	21 5/8	1 1/2	2 1/2
KCB-18	31	28	29 1/2	32	17 1/4	31 1/4	35	24 1/4	24 1/4	2	3
KCB-20	35	31	33	34	19 1/2	33 1/2	37	27 1/4	27 1/4	2	3
KCB-22	38	34	36	37	21	36	40	28 1/4	28 1/4	2	3
KCB-24	41	37	39	41	22 1/2	37 1/2	44	30 3/8	30 3/8	2	3

Dimensiones generales / Dimensions

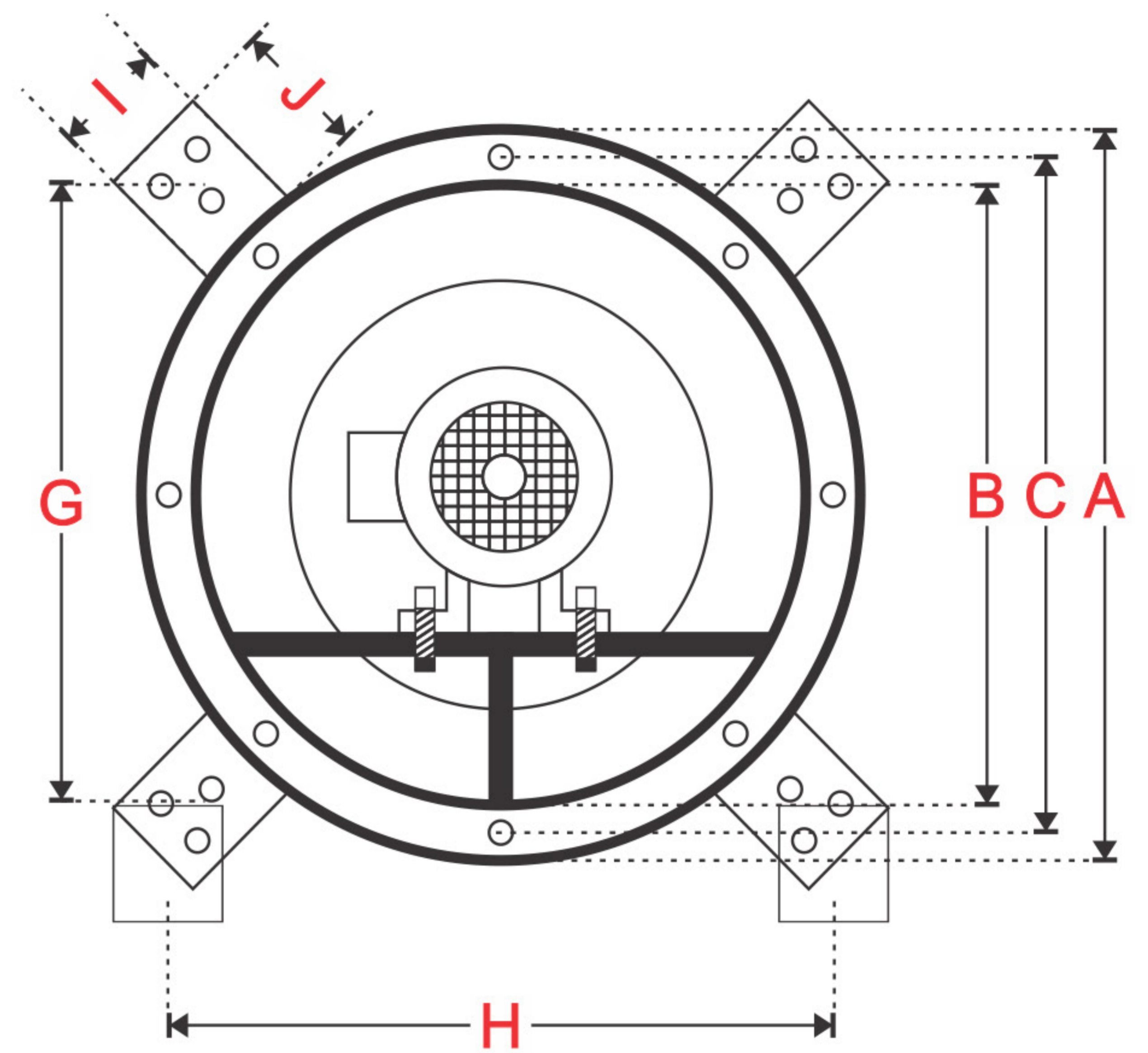
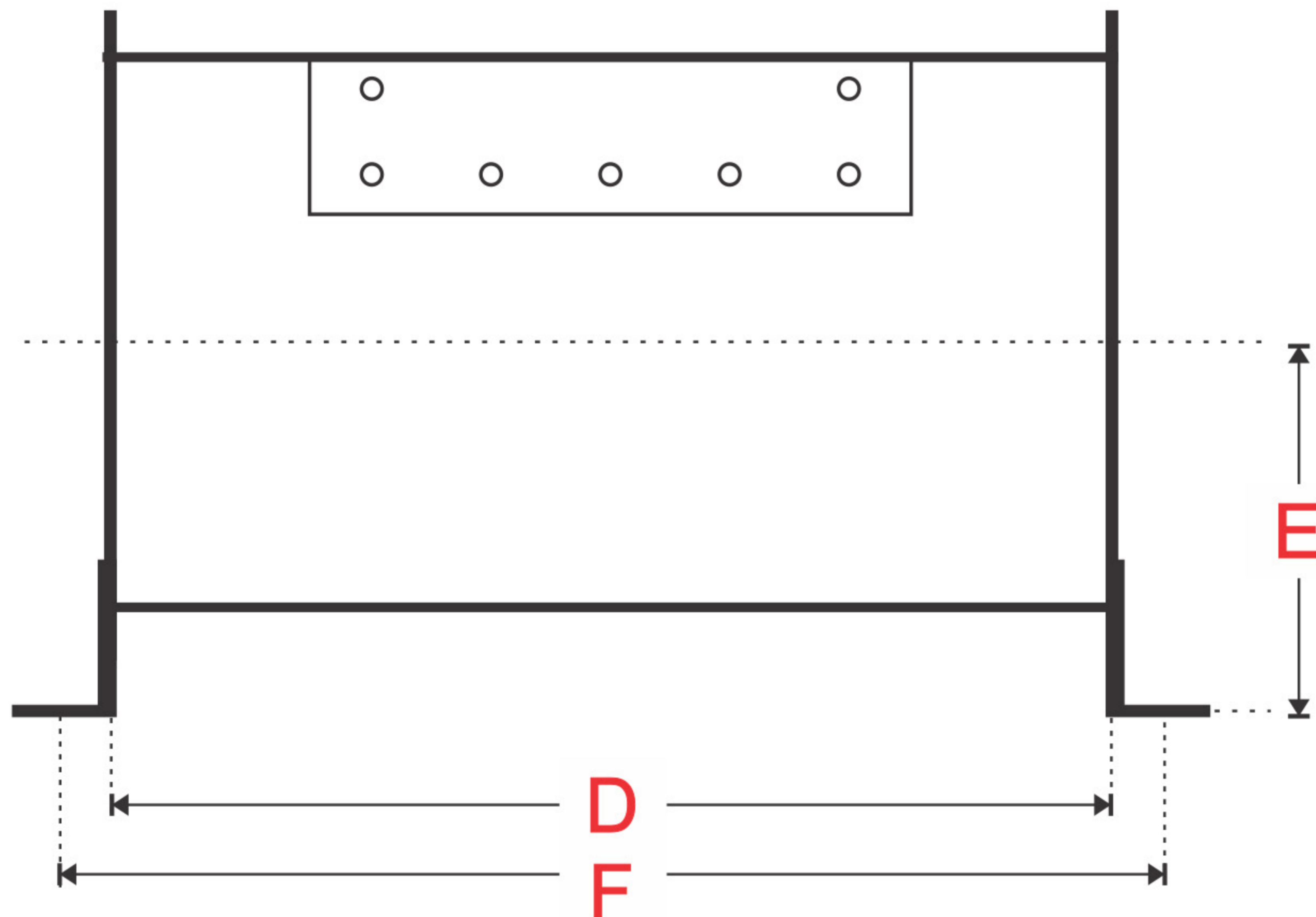

Modelo Model	Pulgadas (Inches)									
	A	B	C	D	E	F	G	H	I	J
KCD-10	19	16	17 1/2	21	11	24	14 1/2	14 1/2	2 1/2	1 1/2
KCD-12	21	18	19 1/2	23	12	26	15 7/8	15 7/8	2 1/2	1 1/2
KCD-13	24	21	22 1/2	26	13 1/2	29	18	18	2 1/2	1 1/2
KCD-15	27	24	25 1/2	28	15 1/4	31	20 1/8	20 1/8	2 1/2	1 1/2
KCD-16	29	26	27 1/2	30	16 1/4	33	21 5/8	21 5/8	2 1/2	1 1/2
KCD-18	31	28	29 1/2	32	17 1/4	35	24 1/4	24 1/4	3	2
KCD-20	35	31	33	34	19 1/2	37	27 1/4	27 1/4	3	2
KCD-22	38	34	36	37	21	40	28 1/4	28 1/4	3	2
KCD-24	41	37	39	41	22 1/2	44	30 3/8	30 3/8	3	2

Dimensiones generales / Dimensions

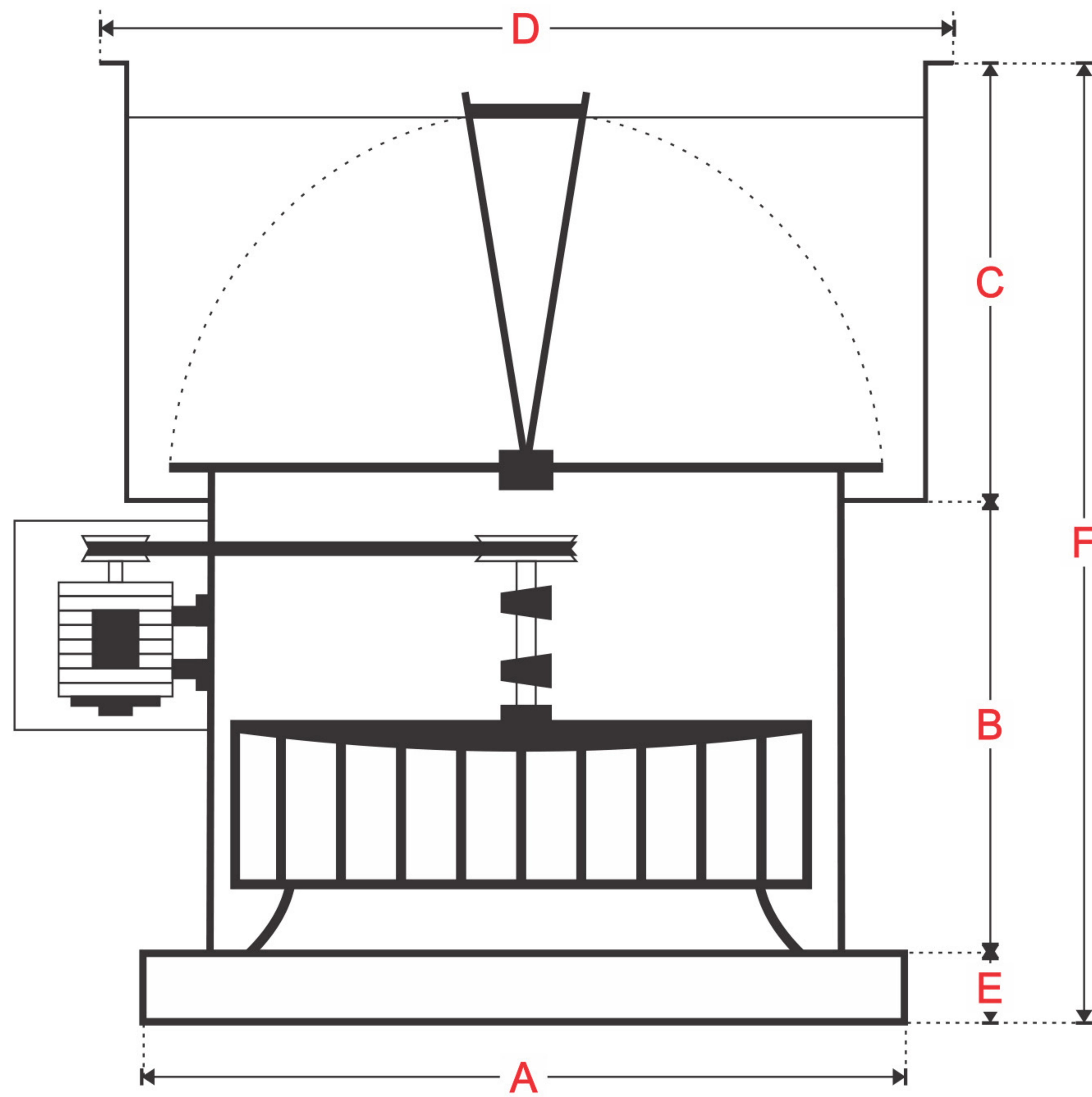

Modelo Model	Pulgadas (Inches)						Peso aprox ventilador Estimated fan weight *(lbs)	
	A	B	C	D	E	F	Clase I	Clase II
KCBR-10	22	19	14 1/2	23	2 3/4	36 1/4	83	90
KCBR-12	24	21	15 1/2	25	2 3/4	39 1/4	112	121
KCBR-13	27	24	17	28	2 3/4	43 3/4	140	149
KCBR-15	30	26	18 1/2	31	2 3/4	47 1/4	150	163
KCBR-16	32	28	19 1/2	33	2 3/4	50 1/4	229	250
KCBR-18	34	30	20 1/2	35	2 3/4	53 1/4	234	253
KCBR-20	38	32	22 1/2	39	2 3/4	57 1/4	293	319
KCBR-22	41	35	24	42	2 3/4	61 3/4	438	463
KCBR-24	44	39	25 1/2	45	2 3/4	67 1/4	524	607

* Peso ventilador sin motor y transmisión

* Fan Weight without motor and drive

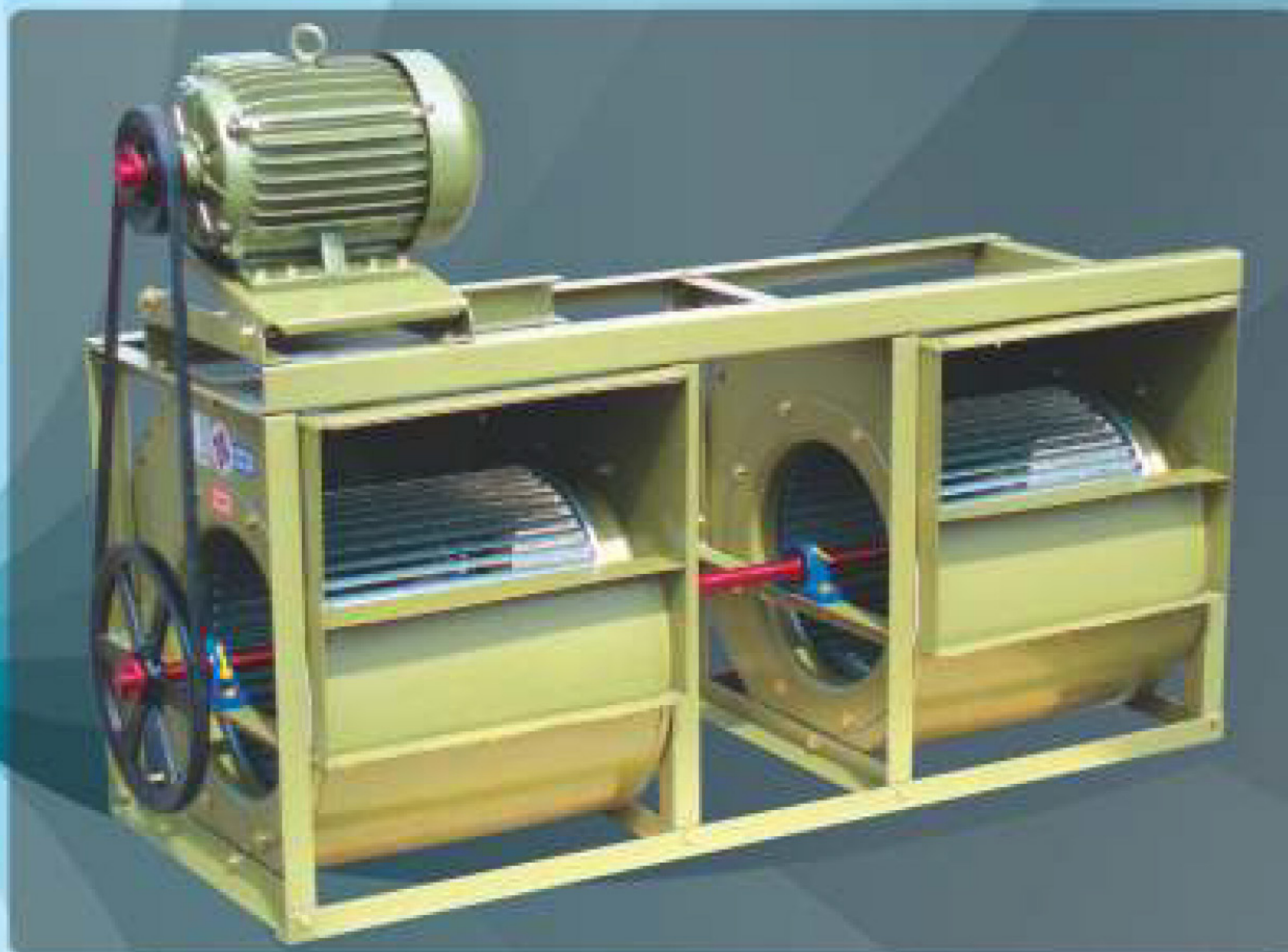

OFICINAS:
Cerrada José Rivera No. 3
Col. Colinas del Bosque,
Corregidora Querétaro

CONTACTO:
442 721 34 12
442 106 35 73 - Vía Whatsapp
lidia@dasseringeneria.com
equiposindustriales@dasseringeneria.com
contacto@dasseringeneria.com